



ELEKTROAKUSTISCHE MANUFAKTUR

randomRHYTHM

Bedienungsanleitung
User Guide

Foreword

Whether random really exists or is just an illusion, shall be discussed by philosophers and mathematicians.

At VERMONA, we found a possibility to add a musical dimension by taking advantage of randomness. At the same time, we will leave the full control over all happenings to you. We even managed to design randomRHYTHM as a unit that is really easy and intuitive to use.

Once started, randomRHYTHM will deliver countless trigger-patterns for your drum-modules.

And maybe, at random people will start dancing ...

Enjoy creating rhythms with the unique combination of random and your own creativity.

Your VERMONA crew from the
Elektroakustische Manufaktur, Erlbach

Unpacking

To ensure top quality, we carefully checked the randomRHYTHM module before packaging. Nevertheless, we cannot fully exclude damage during transportation. Therefore, we kindly ask you to inspect randomRHYTHM by yourself, once you receive the module. In case there is anything unusual about the unit or its packaging, do not hesitate to contact your dealer or us, to solve the problem.

You should find the following items in the box:

- the randomRHYTHM module
- one ribbon cable (10-pole to 16-pole)
- four M-type screws 3 x 6 mm with matching plastic washers
- this operating manual

Setup

randomRHYTHM was designed to be mounted and used in Eurorack modular systems. Its power supply, connectors and dimensions match the typical specifications (VERMONA Modular Case, Doepfer A-100 and compatible systems). Mounting equals any other Eurorack module.

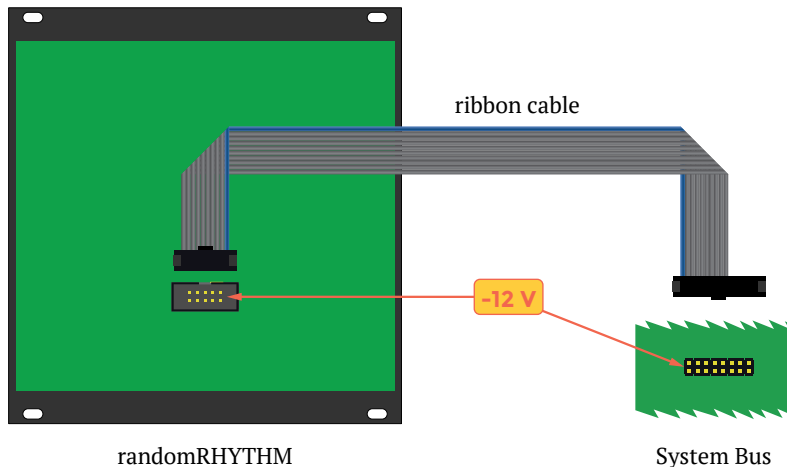

Figure 1: Connecting randomRHYTHM to the systembus

1. **Switch off the power supply!** For safety reasons, also remove the detachable power cord from your frame before mounting the module!

2. Connect the supplied ribbon-cable with its 10-pole connector to the corresponding multi-pin connector on randomRHYTHM's rear (see [Figure 1 on page 23](#))!



The corresponding plug socket is protected against reverse polarity. Therefore, the 10-pole connector of the ribbon-cable will only fit in one direction into the module. The supplied ribbon-cable is color-coded at the -12 volts position. Note, that this may differ from other manufacturers. Therefore, only use the supplied ribbon-cable to connect randomRHYTHM to your frame's system bus!

3. Connect the ribbon-cable's 16-pole connector to an empty plug-socket of your frame's system bus! Make sure the color-coded side of the cable points towards -12 volts (see [Figure 1 on page 23](#))!



Connecting the ribbon-cable with reverse polarity can lead to damage of your randomRHYTHM or other modules when powering the system! Double-check the connections before continuing – safe is safe!

4. Mount randomRHYTHM to your modular frame using the supplied screws! To protect the unit's surface from scratches, use the supplied flat plastic washers.
5. Reconnect the power cord to your frame and switch on the power-supply. randomRHYTHM is now ready to operate.

Overview

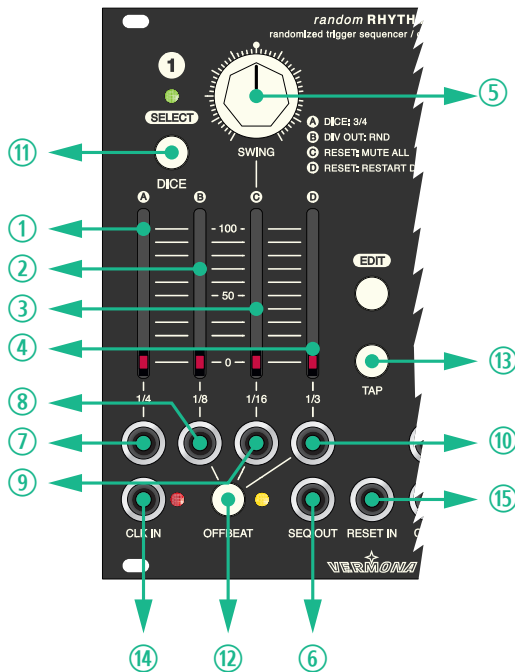

Figure 2: randomRHYTHM's control elements

randomRHYTHM is a trigger-sequencer with two identical rhythm-sections which can be used independently or in parallel. It allows to control drum-modules, envelopes, electronic switches etc. The trigger-sequences are being varied by sliders (①, ②, ③, ④) and send to a summed ⑥ and four individual outputs per rhythm-section (⑦, ⑧, ⑨, ⑩).

randomRHYTHM generates its rhythmical patterns by using the principle of chance. However, the randomness can be dosed to keep the results useful in a musical way.

In addition, the module can be used as source for precise clock-signals, providing four different rhythmic resolutions per rhythm-section. Of course, randomRHYTHM can also be synchronized to external clock-signals.

⑮ Are you eager to start playing with the module? Let us first explain the basic concept of this special sequencer. Understanding this is necessary in order to achieve the best possible results from randomRHYTHM. So please give us a little bit of your attention.

The concept

Contemporary music is dominated by 4/4-beats. In particular, this is true for electronic music. Four-to-the-floor is simply really danceable and therefore reflected in electronic sequencers, clocks and dance music in general. Think of a typical rhythm-sequencer with its controls for step-programming. In most cases, you will find these units to work with 16 subdivisions per bar.



For musical beats referring to rhythm, different terms have been established: steps, beats, hits. Because randomRHYTHM does not offer manually programmable steps, we decided to use the term *event* in this manual.

According to perspective, a 4/4-bar includes a specified number of quarters, eights, sixteenth notes or even triplets. randomRHYTHM follows this scheme in a special way. To illustrate this, let's take a look of what happens at the summing output **SEQ OUT** ⑥.

randomRHYTHM breaks down the musical beats in a simple and logic way. It starts with the 1/4-events:

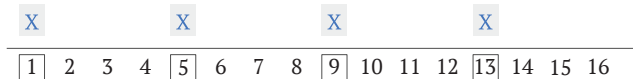

Figure 3: 1/4-events at the SEQ OUT

The next finer partitioning are the $1/8$ -events. Typically, these include also the $1/4$ -events on the positions 1, 5, 9 and 13. However, the output **SEQ OUT**  ignores these four positions. $1/8$ -events only refers positions 3, 7, 11 and 15:



Figure 4: $1/8$ -events at the SEQ OUT

By combining both rows, the result is a continuous pattern:

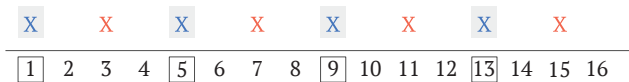

Figure 5: $1/4$ - and $1/8$ -events at the SEQ OUT

The $1/16$ -events follow the same concept. Again, not all events are considered, but only those that are NOT $1/4$ - or $1/8$ -events:



Figure 6: $1/16$ -events at the SEQ OUT

By combining all three rows, the result is a continuous sixteenth-pattern:



Figure 7: 1/4-, 1/8- and 1/16-events at the SEQ OUT

In addition, randomRHYTHM can generate triplets. These again follow the same concept. Because only three *events* per 1/4-note exist, which are being located between the 1/8- and 1/16th-events, overlapping only occurs with 1/4-events. Accordingly these are being left out:



Figure 8: 1/3-events at the SEQ OUT

When combined with the 1/4-events, the result is a continuous pattern of triplets:



Figure 9: 1/4- and 1/3-events at the SEQ OUT

So much for the basic concept of randomRHYTHM. The following chapters will tell you how to use these functions and the resulting possibilities.

The right amount of random

The generation of steady trigger-signals equals the function of a clock-generator. However, randomRHYTHM is designed as a complex sequencer which introduces the element of random into play. This can be individually dosed for 1/4-, 1/8-, 1/16- and 1/3-events.

Each *event* contains a value which is created by random. This *random-value* can neither be seen nor be influenced.



To keep it simple we describe the *random-value* to be in a range between 0 and 100. Indeed, the module's randomizer works much more complex. However, our simple description is enough to understand the principle behind.

An 1/8-figure being combined of 1/4- and 1/8-events (as described above), may look like this:



Figure 10: 1/4- and 1/8-events with their random-values at the SEQ OUT

This is where the sliders ①, ②, ③ and ④ come into play. These adjust a threshold which also lies between 0 and 100. Whenever the slider's value is equal or greater than the *event's random-value*, a trigger-signal will be generated and send out.

Simply put: the higher the slider is set, the higher the number of trigger-signals being sent to the output **SEQ OUT** ⑥. With the value being set to 100 (slider fully up), all trigger-impulses of the corresponding musical beat are being generated, while no trigger-impulses are generated with the slider set to zero (fully down).

There is a lot of wiggle room between 0 and 100 and this is where the fun starts with randomRHYTHM. Let's go back to the example above:



With the slider **1/4** ① set to 50, only the first trigger-impulse is being sent. Increasing the slider to 75 leads to an output of the first and third impulses. And when set to 100, all four impulses are being sent: *fout-to-the-floor*.

The rows **1/8** ②, **1/16** ③ and **1/3** ④ behave the same way. For visual support, the LED of each slider will light up with each trigger-signal being generated. This allows you to visually follow the rhythms.

Let's move into practice. Carry out the following setting and you will immediately understand the concept of randomRHYTHM and get to work target-oriented.

1. Patch the output **SEQ OUT** ⑥ to the trigger-input of a drum-module (i.e the twinCUSSION).
2. Set the slider **1/4** ① to 100 and **1/8** ② to a value of 75. In addition, set the slider **1/16** ③ to a value of approx. 25.

You will now hear all *1/4-events*, almost all *1/8-events* and sometimes a *1/16-event*.

3. Now move the sliders **1/8** ② and **1/16** ③. You will immediately hear the number of the corresponding trigger-signals change.

Positive and negative swing

By using the **SWING** control ⑤, the trigger-impulses of the even 1/16-events can be pulled forward or delayed. The control works bipolar, meaning that its center-position equals a swing-value of zero (no swing). By turning **SWING** ⑤ to the right, the corresponding notes will be delayed. By turning the control to the left, the notes are pulled before the beat:





Figure 11: 1/16-events can be pulled forward or delayed via SWING



With the slider 1/16 ③ being set to zero, no swing effect will be audible, even with the SWING control ⑤ set to do so.

Everything thrown together again

When starting randomRHYTHM for the first time, it is in so-called dice-mode. Dice-mode is always indicated by the green LED above the **DICE**  button being lit.

In this mode the randomized pattern is repeated after each third or fourth quarter, depending on the bar-setting (see “A - DICE 3/4” on page [58](#)). By shortly pressing the **DICE** button , new random-values for all events and for a complete 4/4-bar are being generated.

In randomRHYTHM the opposite of the dice-mode is the realtime-mode. Here new random values are generated all the time.

To switch into realtime-mode simply press and hold the **DICE**  button for one second until the corresponding LED goes out. Realtime-mode is now activated. To switch back just press **DICE**  again.



randomRHYTHM remembers the last state before switching the unit off. In case, dice-mode has been enabled by that time, the mode will also be active after switching the unit back on – including the generated *random-values* for the events. This way, you can continue working on your track using the same pattern.

Single or multiple output?

The trigger-patterns being defined by the sliders can be send to other modules in two ways.

So far, we have described the functions of randomRHYTHM when using **SEQ OUT** ⑥ to output the trigger-patterns. This output contains the logical sum of the four subdivisions 1/4, 1/8, 1/16 and 1/3. It can be used to trigger a single drum-sound such as a hihat, any percussion instrument as well as an envelope - everything that wants a trigger-signal.

The second method to output trigger-signals is to use the individual outputs **1/4** ⑦, **1/8** ⑧, **1/16** ⑨ and **1/3** ⑩. These allow to distribute the trigger-signals to several modules.

On- and Offbeat

The individual outputs **1/8** ⑧, **1/16** ⑨ and **1/3** ⑩ offer two operating modes. Toggle between these modes by using the **OFFBEAT** ⑫ switch per rhythm-section.

With **OFFBEAT** ⑫ being active (corresponding yellow LED lit), the individual outputs **1/8** ⑧, **1/16** ⑨ and **1/3** ⑩ send out the trigger-impulses as being described in “The concept” on page 26. In this mode the individual outputs work exactly like the divisions on the **SEQ OUT** output ⑥.

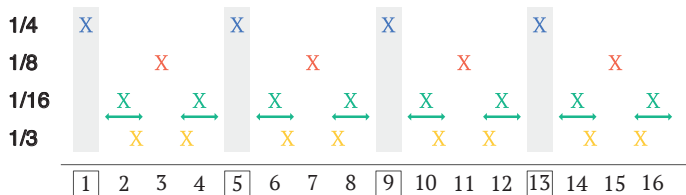

Figure 12: Events at the individual outputs with activated OFFBEAT

With **OFFBEAT** ⑫ being disabled (corresponding yellow LED turned off), the outputs **1/8** ⑧, **1/16** ⑨ and **1/3** ⑩ work at their real resolution.

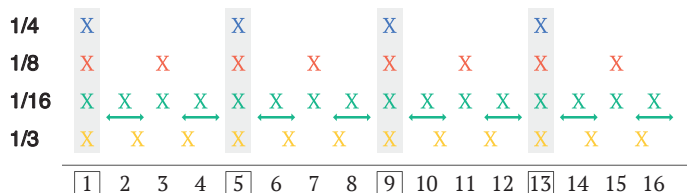

Figure 13: Events at the individual outputs with deactivated OFFBEAT

In both **OFFBEAT** ⑫ settings (on/off), the sliders ①, ②, ③ and ④ still influence the generated trigger-impulses on the individual outputs ⑦, ⑧, ⑨, ⑩ or the main **SEQ OUT** output ⑥. Unless ...

... random has been switched off for the rhythm-section. In this case, the individual outputs will provide continuous clock-signals equaling the values of their labelings. At **1/4** ⑦, these are four impulses per beat, eight impulses at **1/8** ⑧ and so on. In this operating mode, randomRHYTHM can be used as a multiple clock-source even including clock-multiplication.

Switching off random is described in chapter “**B - DIV OUT: RND**” on page 58. At factory default, the random mode is of course enabled. After all, this is core of randomRHYTHM.

Here we go

randomRHYTHM uses a constantly running internal clock to drive the module. When switching the unit resp. the modular system on, the clock and the sequencer will automatically start, given that no cables have been patched to one or both **CLK IN** inputs ⑭.

The tempo is determined by pressing the **TAP** button ⑮. By repeatedly pressing this button with a constant tempo, the desired speed is being set. Each hit of the **TAP** button ⑮ equals a quarter-note. randomRHYTHM only need two presses to adjust to a new tempo. This way, you may easily set a new tempo while the unit is running.

Using an external clock

Whenever an external clock-signal is applied at any of the two **CLK IN** inputs ⑭, it will determine the tempo for both sections.

By pressing the **TAP** button ⑮ twice, the internal clock will be re-enabled for the section where the **CLK IN** input ⑭ is not in use.

By pressing and holding the **TAP** button ⑮ for one second, the external clock of the other rhythm-section takes over control again.

Likewise it is possible to synchronize both sections with different external clock-sources. You may also tap a clock-signal from section 1 and route it to the **CLK IN** input ⑭ of section 2.

EDIT functions

General

There are four additional settings that can be adjusted for each section. These settings will be preserved when switching the unit off.

For the EDIT parameter, the **DICE** buttons of rhythm-section 1 and 2 have different functions: **SELECT** (DICE 1) and **SET** (DICE 2).

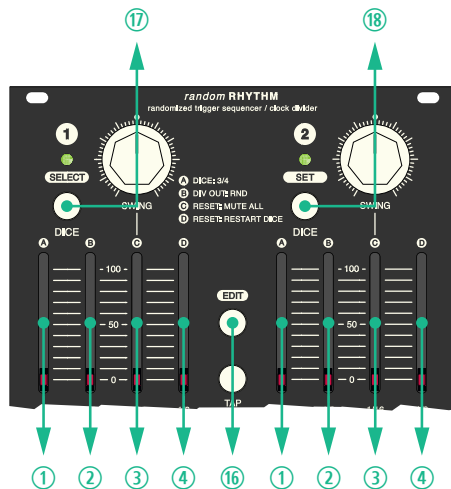

Figure 14: randomRHYTHM's control elements in EDIT mode

EDIT parameters are called up as follows:

1. Press the **EDIT** button ⑯. The green LED above the **SELECT** button ⑰ will start flashing. In addition, the red LEDs of the sliders ①, ②, ③ and ④ will no longer be flashing. Instead, the LEDs of the active EDIT parameter light up permanently.
2. By repeatedly pressing **SELECT** ⑰, functions **A**, **B**, **C** and **D** for rhythm-sections 1 and 2 are selected one after another. By doing so, the LED of the corresponding selected slider flashes.
3. By pressing **SET** ⑱, the green SET-LED will be lit and the corresponding parameter enabled.
4. By pressing the **EDIT** ⑯ button once more, the edit-mode is ended.

The red LEDs of the sliders ①, ②, ③, and ④ visualize the switching in two ways. The parameter that has been selected using **SELECT** ⑰ has a flashing LED. If a parameter has been enabled the corresponding LED of the slider flashes with real short stops. If a parameter has been disabled, the corresponding LED of the slider flashes with longer interruptions.

For the other seven sliders, which are currently not being selected, the red LEDs are lit for enabled parameters and off for disabled parameters.



When first entering the EDIT menu after switching the unit on, no parameter is selected. Therefore, no LED is flashing.

When calling up the EDIT menu multiple times, it will always jump to the last selected parameter, indicated by a flashing LED.

randomRHYTHM keeps running when entering the edit-menu.

A - DICE 3/4

The factory-setting of randomRHYTHM is a 4/4-beat-resolution, with dice-mode enabled. However, it is possible to switch to a 3/4-beat. By combining both rhythm-sections with 4/4- and 3/4-beats, the generated patterns are continuously shifted against each other. This can also be interesting when used in combination with external sequencers.

- Parameter active - LED on = 3/4-time
- Parameter inactive - LED off = 4/4-time (factory default)



When hitting DICE, randomRHYTHM always generates random-values for a 4/4-beat, even when EDIT parameter A - DICE 3/4 is activated.

B - DIV OUT: RND

The random-function can be switched off for the individual outputs. In this case, continuous trigger-patterns equalling a clock-signal, are being generated and sent to the corresponding outputs **1/4** ⑦, **1/8** ⑧, **1/16** ⑨ and **1/3** ⑩. Here, the sliders do not carry out any function. However, the **OFFBEAT** button ⑪ can still be used to specify whether all trigger-impulses of the corresponding output will be send or just the impulses that follow the basic concept of the divided pattern (see “Single or multiple output?” on page 53).

- Parameter active - LED on = random (factory default)
- Parameter inactive - LED off = continuous clock-signal

RESET

Functions **C** and **D** specify the operating mode of the input **RESET IN** ⑤. Only one of the two functions can be enabled per rhythm-section, since these functions are mutually exclusive. Without any function being activated, the input **RESET IN** ⑤ takes no influence on the corresponding rhythm-section.

C - RESET: MUTE ALL

With this function being enabled, the **RESET IN** input ⑤ allows to mute all trigger-outputs (**1/4** ⑦, **1/8** ⑧, **1/16** ⑨, **1/3** ⑩ and **SEQ OUT** ⑥). Whenever a permanent, positive voltage above 2 volts is applied to input **RESET IN** ⑤, no trigger-impulse will be sent out to the corresponding outputs. Once the voltage drops below 2 volts, the outputs will be released again.

D - RESET: RESTART DICE

This function is only active in dice-mode. With this function being enabled, a trigger-impulse (positive slope) can be used to reset the active pattern to its start.



The operating mode for RESET IN ⑤ may differ for the rhythm-sections 1 and 2. This leads to interesting rhythmical effects.

For example: connect a square-wave-LFO to the RESET IN input ⑤ with RESTART DICE activated for rhythm-section 1 and MUTE ALL activated for rhythm-section 2. At the LFO's rising slope, rhythm-section 1 is being restarted, while rhythm-section 2 is being muted for the duration of the positive half-cycle of the square-wave. With the slope descending, the trigger-impulses for section 2 are sent again.

Technical Specification

Trigger

Threshold (inputs).....	+ 2 V
Trigger properties (outputs)	+ 10 V, 10 ms

Maximum Power Consumption

+ 12 V	110 mA
- 12 V	-
+ 5 V	-

Dimensions / Weight

Width / Height	24 HP, 3 U
Depth	25 mm
Weight	230 g



VERMONA

ELEKTROAKUSTISCHE MANUFAKTUR

**HDB electronic GmbH
Badesteig 20
08258 Markneukirchen
GERMANY**

**Phone +49 (0) 37422 4027 - 0
Email info@vermona.com
Web www.vermona.com**