



***User's Manual***

# **SOUND FORCE**

*SF-10 / SF-26 / SF-158 / SF-212 / SF-218*



Antes de utilizar el equipo, lea la sección "Precauciones de seguridad" de este manual. Conserve este manual para futuras consultas.

Before operating the device, please read the "Safety precautions" section of this manual. Retain this manual for future reference.

## CONTENTS

<b>SAFETY PRECAUTIONS</b> .....	<b>3</b>
<b>WARRANTY</b> .....	<b>4</b>
<b>DECLARATION OF CONFORMITY</b> .....	<b>5</b>
<b>INTRODUCTION</b> .....	<b>6 - 7</b>
<b>CONFIGURATIONS</b> .....	<b>8 - 11</b>
<i>4 x SF-221 + 4 x SF-158 (4 WAY) + D series</i>	
<i>4 x SF-221 + 4 x SF-158 (3 WAY) + D series</i>	
<i>4 x SF-221 + 4 x SF-158 (4 WAY) + DX series</i>	
<i>4 x SF-221 + 4 x SF-158 (3 WAY) + DX series</i>	
<i>2 x SF-212 + 4 x SF-10</i>	
<i>2 x SF-212 + 6 x SF-26</i>	
<i>2 x SF-218 + 8 x SF-10</i>	
<i>2 x SF-212 + 8 x SF-26</i>	
<b>LINE DRAWINGS</b> .....	<b>12</b>
<b>SPECIFICATIONS</b> .....	<b>13</b>
<b>INSTALLATION</b> .....	<b>14 - 17</b>
<b>ACCESSORIES</b> .....	<b>18 - 22</b>
<b>ANNEX : Table for cable selection</b> .....	<b>23</b>

# SOUND FORCE



SF-10 / SF-26 / SF-158 / SF-212 / SF-218  
Cajas acústicas pasivas / Passive loudspeaker enclosures

Precauciones de Seguridad  
Safety Precautions

Conserve y lea todas estas instrucciones.

Siga todas las advertencias.

El signo de exclamación dentro de un triángulo indica la existencia de componentes internos cuyo reemplazo puede afectar a la seguridad.



Keep these instructions.

Heed all warnings. Follow all instructions.

The exclamation point inside an equilateral triangle indicates the existence of internal components whose substitution may affect safety.

El doble cuadrado indica equipo de Clase II.



The double square indicates Class II device.

Las especificaciones se encuentran en la etiqueta de la parte posterior del producto.

The specifications can be found on the rear label of the product.

El colgado del equipo sólo debe realizarse utilizando los herrajes de colgado recomendados y por personal cualificado. No cuelgue la caja de las asas.

The appliance should be flown only from the rigging points and by qualified personnel. Do not suspend the box from the handles.

No exponga este equipo a la lluvia o humedad. No exponga el equipo a salpicaduras ni coloque sobre él objetos que contengan líquidos, tales como vasos y botellas. Equipo IP-20.

Do not expose this device to rain or moisture. Do not place any objects containing liquids, such as bottles or glasses, on the top of the unit. Do not splash liquids on the unit. IP-20 equipment.

Este símbolo indica que el presente producto no puede ser tratado como residuo doméstico normal, sino que debe entregarse en el correspondiente punto de recogida de equipos eléctricos y electrónicos.



This symbol on the product indicates that this product should not be treated as household waste. Instead it shall be handed over to the applicable collection point for the recycling of electrical and electronic equipment.

Equipo diseñado para funcionar entre -25°C y 45°C. La humedad relativa máxima del 95%.

Working temperature ranges from -25°C to 45°C. The maximum relative humidity of 95%.

El cableado exterior conectado al equipo requiere de su instalación por una persona instruida o el uso de cables flexibles ya preparados.

The outer wiring connected to the device requires installation by an instructed person or the use of a flexible cable already prepared.

El equipo cuenta con dos conectores de entrada en paralelo para facilitar la conexión de varias cajas en paralelo.

Note that the two Speakon input connectors are wired in parallel to provide easy parallel connection of several enclosures.

No emplace altavoces en proximidad a equipos sensibles a campos magnéticos, tales como monitores de televisión o material magnético de almacenamiento de datos.



Do not place loudspeakers in proximity to devices sensitive to magnetic fields such as television monitors or data storage magnetic material.

Para las cajas con vaso para trípode, la altura máxima de seguridad desde el suelo a la base de la caja montada sobre trípode modelo TRD-2, con pies a 55 cm del eje del trípode, es:

SF-26-----> 130 cm  
SF-10-----> 125 cm

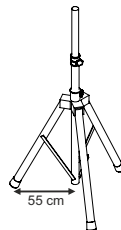

For enclosures with tripod socket, the maximum safety height from floor to bottom of enclosure when mounting on a TRD-2 tripod, with legs spread 55cm from the central pole, is:

SF-26-----> 130 cm  
SF-10-----> 125 cm

No existen partes ajustables por el usuario en el interior de este equipo. Cualquier operación de mantenimiento o reparación debe ser realizada por personal cualificado. Es necesario el servicio técnico cuando el aparato se haya dañado de alguna forma, tal como que haya caído líquido o algún objeto en el interior del aparato, haya sido expuesto a lluvia o humedad, no funcione correctamente o haya recibido un golpe.

No user serviceable parts inside. Refer all servicing to qualified service personnel. Servicing is required when the apparatus has been damaged in any way, such as power-supply cord or plug is damaged, liquid has been spilled or objects have fallen into the apparatus, the apparatus has been exposed to rain or moisture, does not operate normally or has been dropped.

Limpie con un paño seco. No use limpiadores con disolventes.

Clean only with a dry cloth. Do not use any solvent based cleaners.

## **GARANTÍA**

Todos nuestros productos están garantizados por un periodo de 24 meses desde la fecha de compra.

Las garantías sólo serán válidas si son por un defecto de fabricación y en ningún caso por un uso incorrecto del producto.

Las reparaciones en garantía pueden ser realizadas, exclusivamente, por el fabricante o el servicio de asistencia técnica autorizado.

Otros cargos como portes y seguros, son a cargo del comprador en todos los casos.

Para solicitar reparación en garantía es imprescindible que el producto no haya sido previamente manipulado e incluir una fotocopia de la factura de compra.

## **WARRANTY**

All our products are warranted against any manufacturing defect for a period of 2 years from date of purchase.

The warranty excludes damage from incorrect use of the product.

All warranty repairs must be exclusively undertaken by the factory or any of its authorised service centers.

To claim a warranty repair, do not open or intend to repair the product.

Return the damaged unit, at shippers risk and freight prepaid, to the nearest service center with a copy of the purchase invoice.



## DECLARACIÓN DE CONFORMIDAD DECLARATION OF CONFORMITY

### **DAS Audio Group, S.L.**

C/ Islas Baleares, 24 - 46988 - Pol. Fuente del Jarro - Valencia. España  
(Spain).

Declara que *SF-10 / SF-26 / SF-158 / SF-212 / SF-218*:

Declares that *SF-10 / SF-26 / SF-158 / SF-212 / SF-218*:

Cumple con los objetivos esenciales de las Directivas:

Abide by essential objectives relating Directives:

- De Baja Tensión / Low Voltage 2014/35/UE
- RoHS 2011/65/UE
- RAEE (WEEE) 2012/19/UE

Y es conforme a las siguientes Normas Armonizadas Europeas:

In accordance with Harmonized European Norms:

- EN 60065:2014.- Audio, video and similar electronic apparatus. Safety requirements.
- EN 50581:2012.- Technical documentation for the assessment of electrical and electronic products with respect to the restriction of hazardous substances.

## INTRODUCTION

The *Sound Force (SF) series* has been designed for today's high-level dance venues where exceptional sound, imposing power and impressive looks are key requisites.

Thanks to the modularity of the series, the designers of the rooms have a variety of combinations to mid-high, medium-low and subwoofers that can be adapted to specific local needs.

Designed for performance and reliability, built to exacting standards *SoundForce* by **DAS Audio**. The first choice for high-level dance clubs worldwide.

### Features

#### SF-26

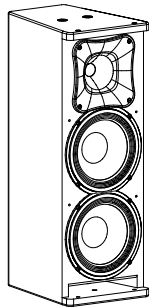

SF-26

- Twin 6" loudspeakers, **6P**
- **M-34** compression driver of 1"
- Vertical or horizontal positioning
- Threaded fixing points for wall mounts
- Pole mount accessories

The *SF-26* employs twin **6P** woofers for low frequency reproduction. The **M-34** compression driver provides brilliant highs. The birch plywood cabinet construction offers an ultra-compact design. Precise coverage and control in either the horizontal and vertical position is possible thanks to the symmetrical 80° horn geometry. The cabinets can be permanently installed by way of the optional "U" brackets and accessories which allow for multiple configurations. Four threaded fixing points for the *AXW-1* adjustable wall mount and stand mounting accessories augment adaptability. A robust steel grille internally lined with acoustically transparent filter cloth protects components. Optional colors are available by special order.

#### SF-10

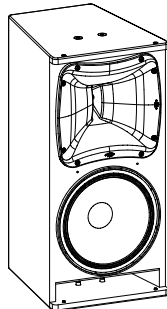

SF-10

- Single 10" loudspeaker
- Compression driver with 1.75" polymer diaphragm
- Threaded fixing points for wall mounts
- Pole mount socket

The *SF-10* employs a single 10" woofer, **10P**, for low frequency reproduction. The **M-60N** compression driver with 1.75" high tech polymer diaphragm provides brilliant highs. The birch plywood cabinet construction offers an ultra-compact design. Precise coverage and control with its 110° x 50° horn geometry. The cabinets can be permanently installed by way of the optional "U" brackets and accessories which allow for multiple configurations. Four threaded fixing points for the *AXW-3* adjustable wall mount and a pole mount socket augment adaptability. A robust steel grille which shares the design scheme of the other *Sound Force* models. Optional colors are available by special order.

### SF-158

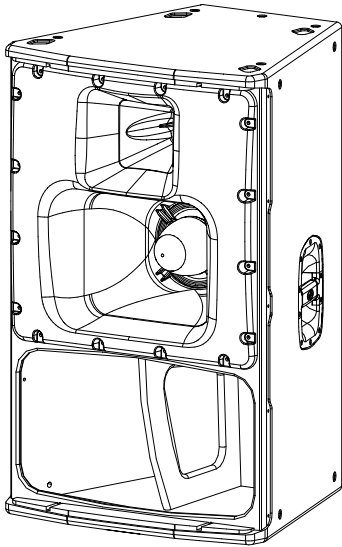

SF-158

- Three-way full-range system
- 1 x **15GNR** horn loaded bass loudspeaker
- 1 x **8AN** horn loaded mid-range loudspeaker
- **M-75N** neodymium compression driver
- Selectable biamp/triamp operating modes
- Tight 40° x 30° coverage angles
- Rotatable horn for vertical or horizontal positioning

The **SF-158** 3-way, full-range system is designed to provide the **Sound Force series** with a powerful stand-alone solution. A horn loaded 15" bass, and an 8" mid range in a bullet-type loading device handle the low to mid range. The **M-75N** neodymium compression driver provides exceptional high frequency reproduction. The **SF-158** can be used in either the vertical or horizontal position thanks to its rotatable mid-high horn assembly. Selectable biamp or triamp operation is possible. Custom colors can be ordered.

### SF-212

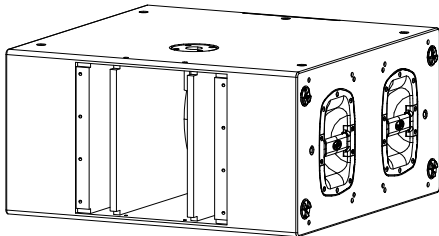

SF-212

- Compact band-pass subwoofer system
- Dual 12" low frequency loudspeakers and 3" coil
- Enclosure designed for an easy stacking

The **SF-212** is a band-pass subwoofer system with dual **12P** low frequency loudspeakers. The loudspeaker is protected by a perforated steel grille, sealed against corrosion using a powder coat finish. The birch plywood cabinet construction offers an ultra-compact design which is available in black or white. The **SF-212** is designed for use in active systems. The handles make moving easy. Custom colors can be ordered.

### SF-218

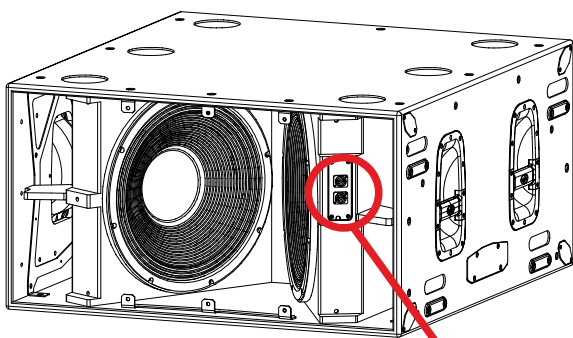

SF-218

- High performance subwoofer system for external amplification
- Two **18UXN** long-excursion loudspeakers
- Front loaded cross-fire configuration
- Solid birch plywood construction

The **SF-218**, make use of two 18" **18UXN** transducers. The new loudspeaker, designed and manufactured by **DAS**, offers impressive features such as a 4" sandwich split winding voice coil, a remarkable 52 mm peak-to-peak excursion, and a powerful FEA optimized neodymium magnet assembly. Thanks to the double silicon spider, the **18UXN** controls the moving mass with high linearity. An aluminum demodulating ring reduces distortion, and effective ventilation of the voice coil gap provides for a high thermal rating and reduced power compression.

**FRONT CONNECTORS  
FOR CARDIOID  
CONFIGURATIONS**

The enclosure is constructed using Birch plywood and makes use of extensive bracing to eliminate resonances. The woodwork is finished with the robust **DAS** ISO-flex protective coating for durability. A dolly platform with locking casters, **PL-UX218S**, is available to stack and move the systems (up to 3 units). Protection during transport is provided by the optional covers available from **DAS**. Custom colors can be ordered.

## CONFIGURATIONS

Next, find eight examples.

### 4 x SF-221 + 4 x SF-158 (4 WAY) + D series

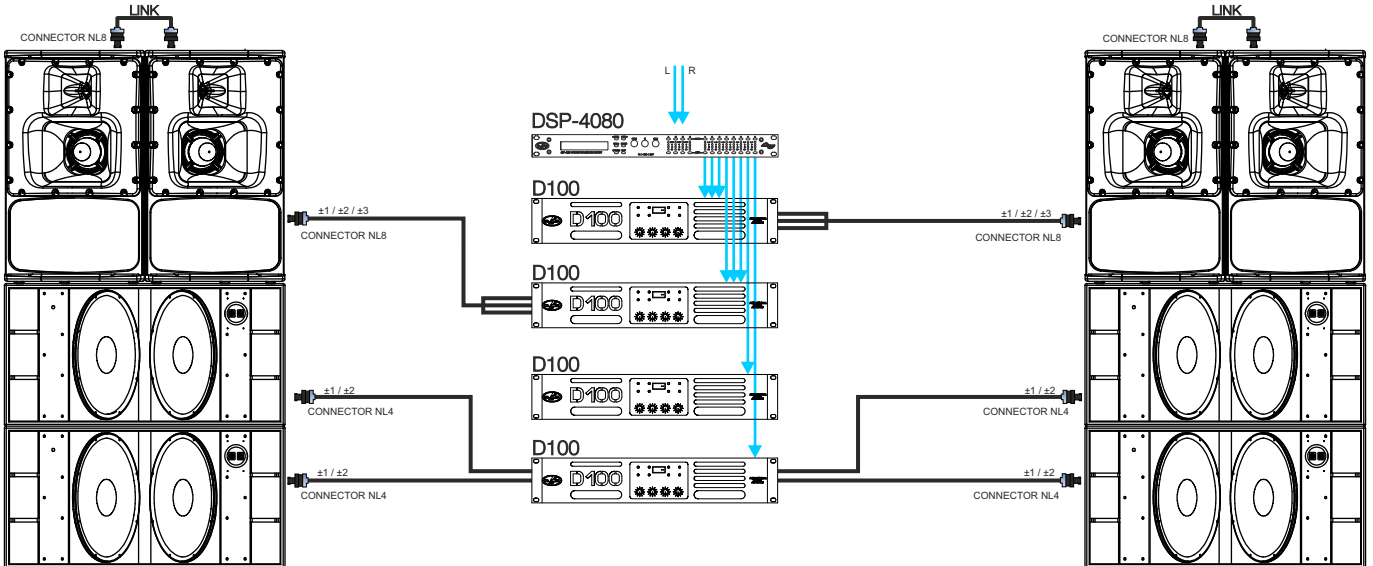

### 4 x SF-221 + 4 x SF-158 (3 WAY) + D series

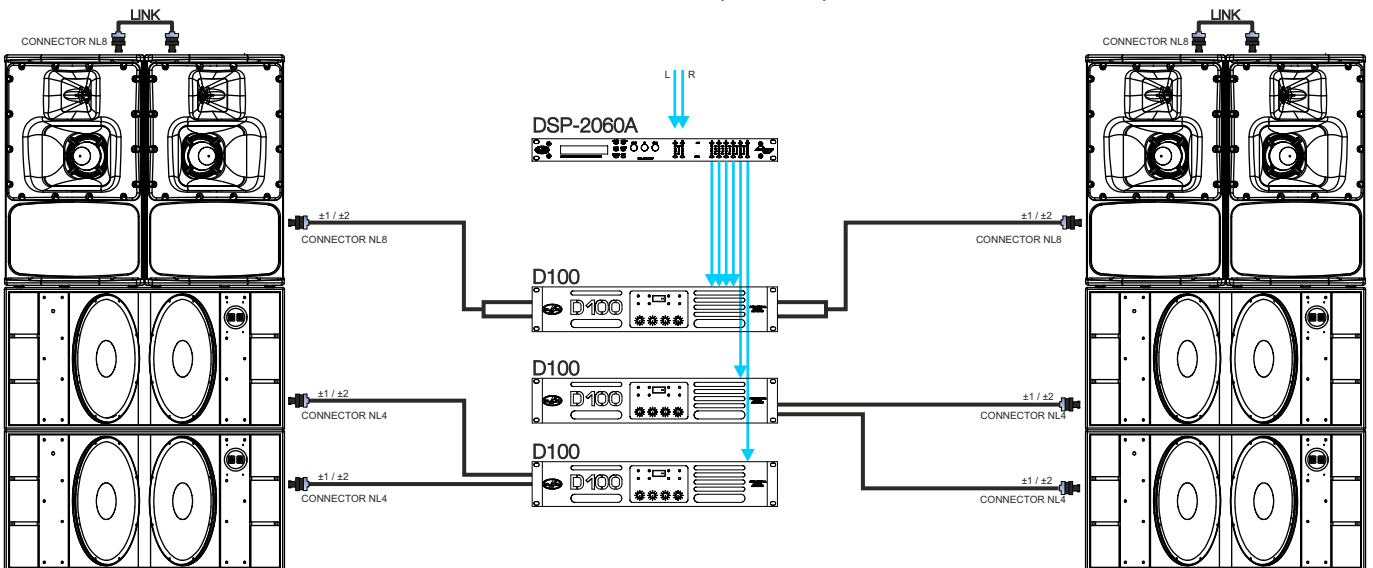



**CONFIGURATIONS (cont'd)**

4 x SF-221 + 4 x SF-158 (4 WAY) + DX series

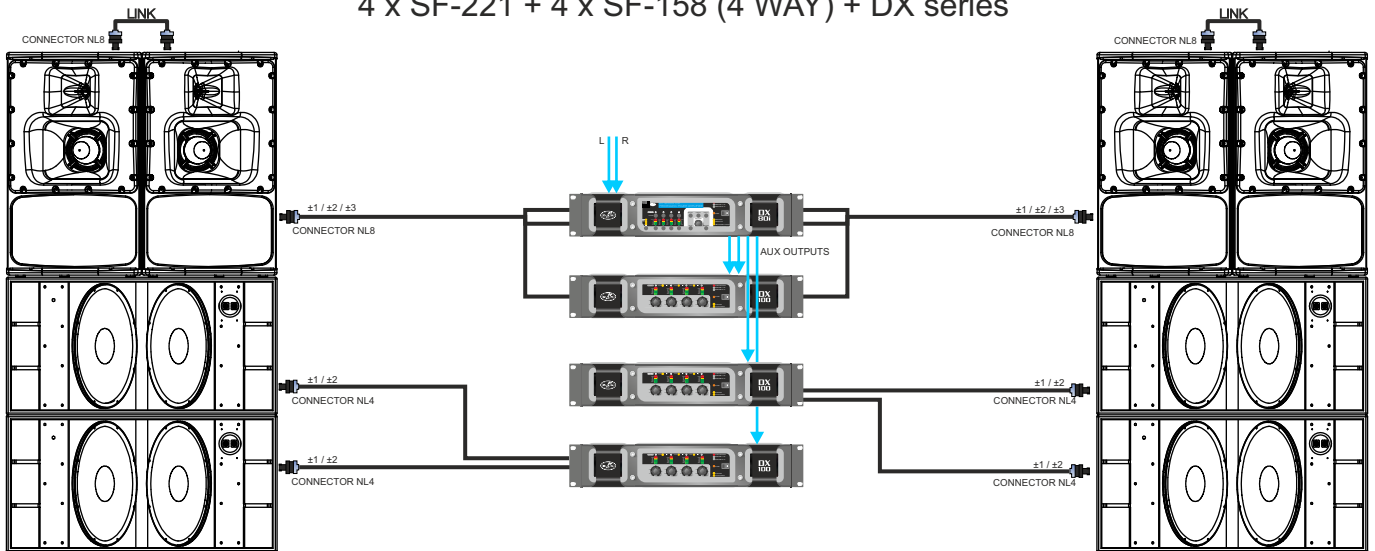

4 x SF-221 + 4 x SF-158 (3 WAY) + DX series

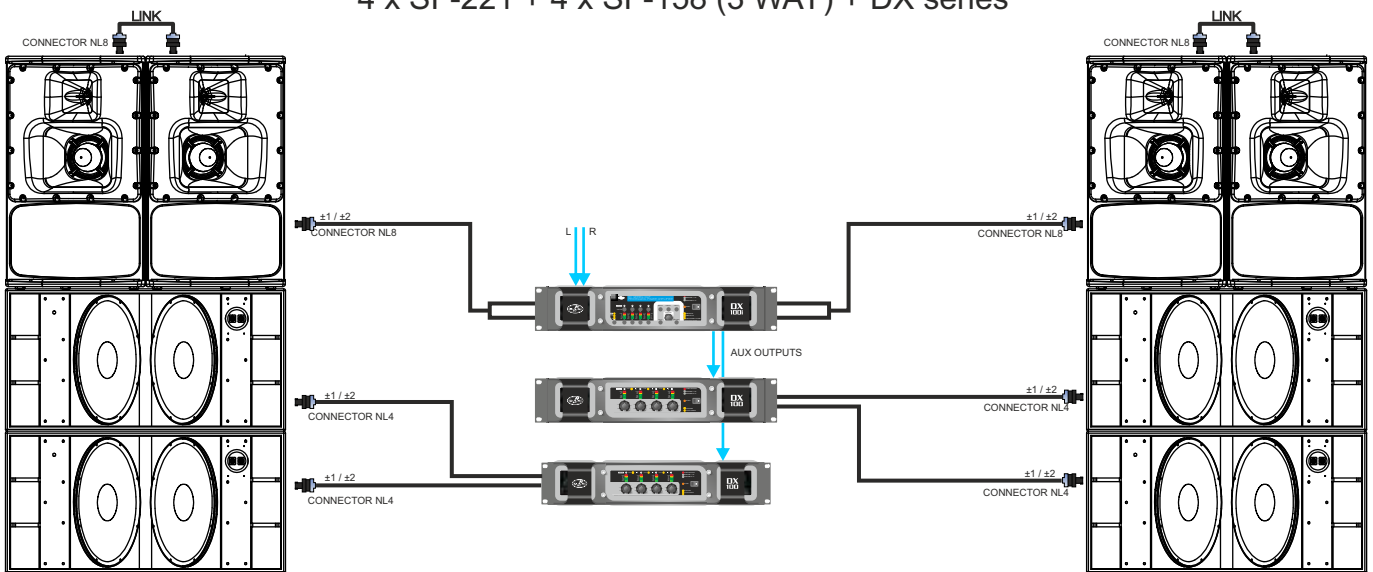

**CONFIGURATIONS (cont'd)**

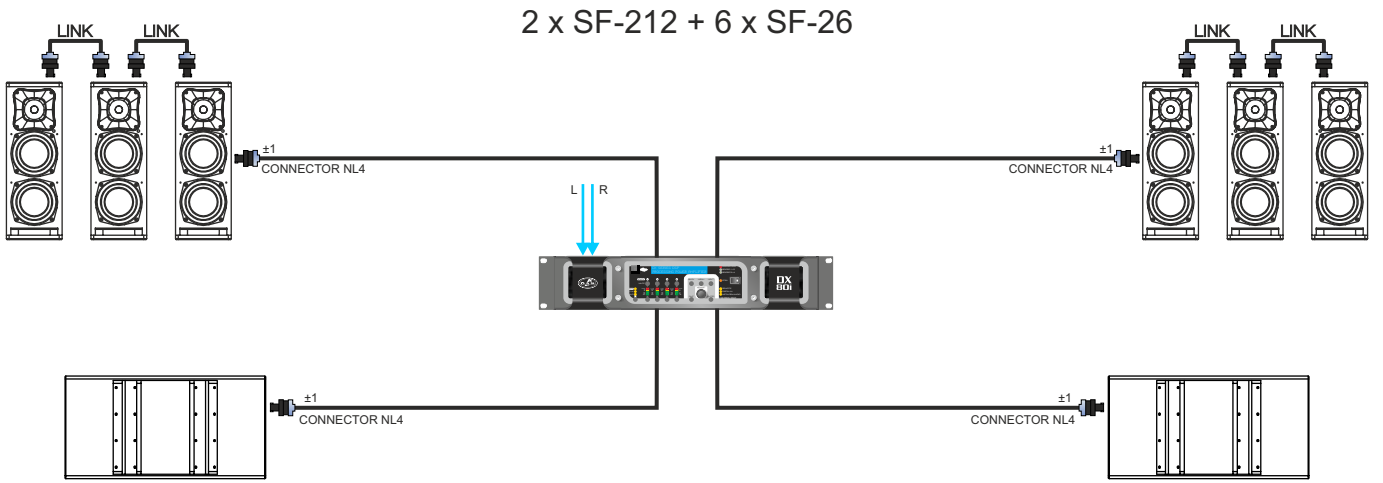
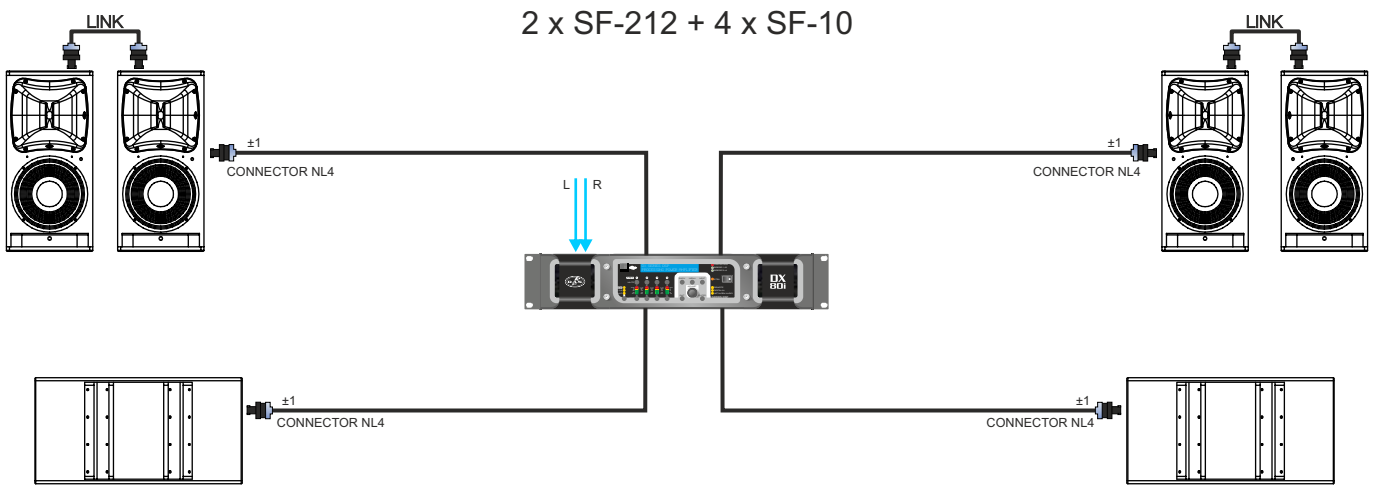

**CONFIGURATIONS (cont'd)**

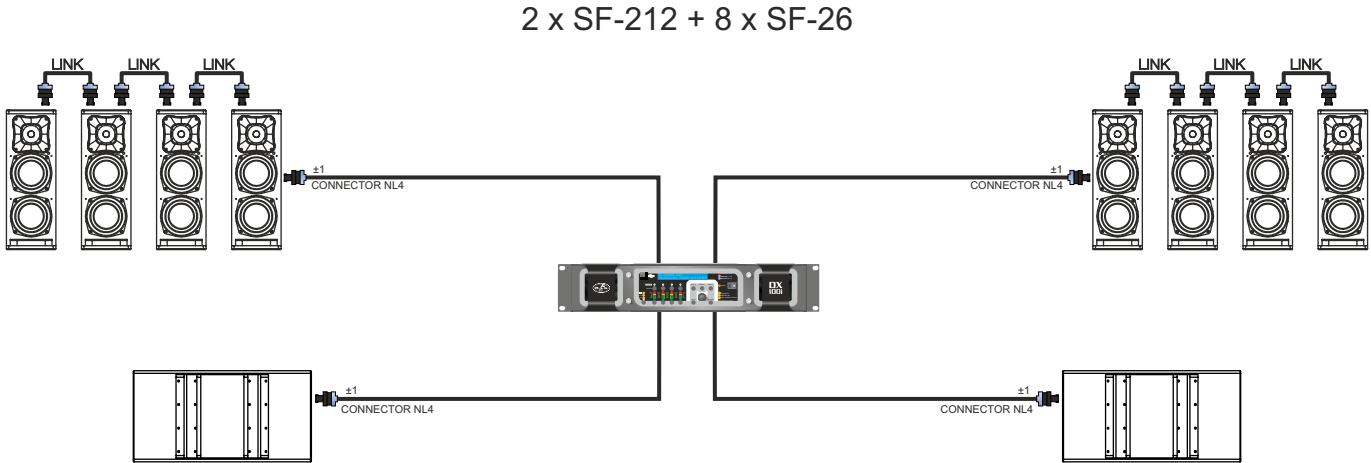
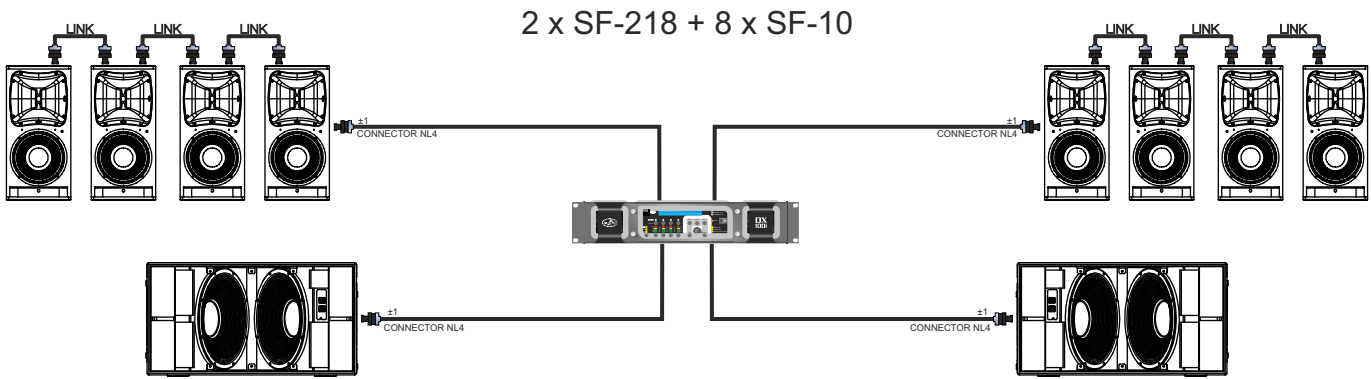

## LINE DRAWINGS

ALL DIMENSIONS IN MILLIMETERS

SF-10

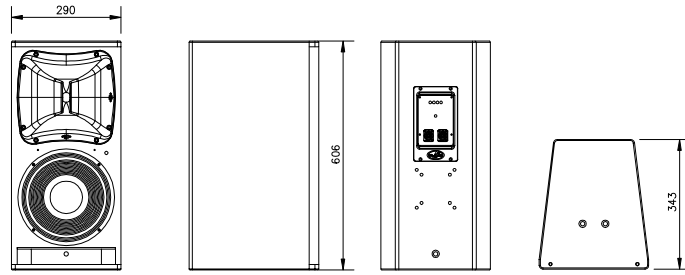

SF-26

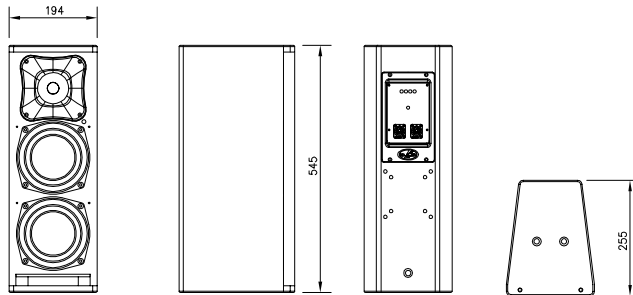

SF-158

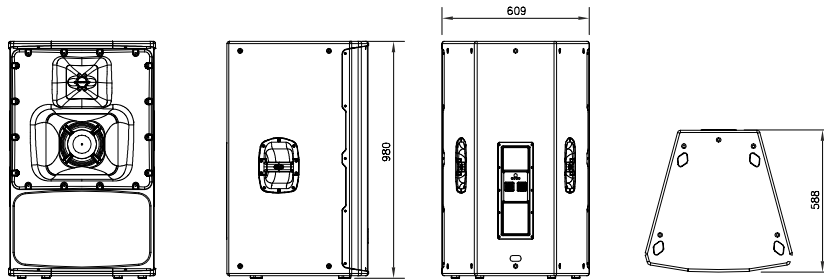

SF-212

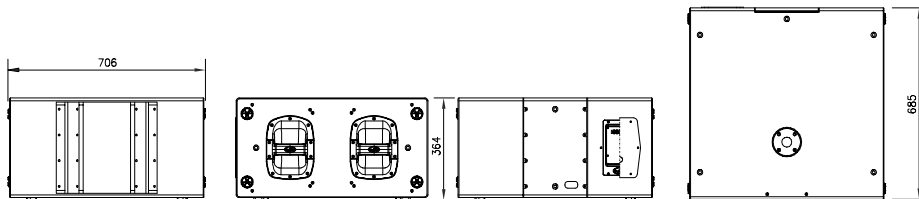

SF-218

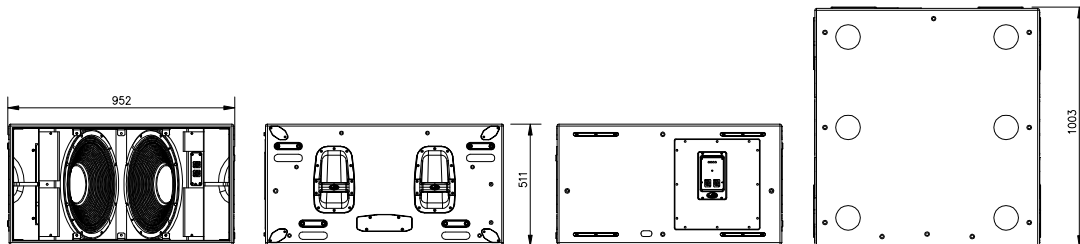

## SPECIFICATIONS

<i>Model</i>	<b>SF-10</b>	<b>SF-26</b>	<b>SF-158</b>	<b>SF-212</b>	<b>SF-218</b>
<b>RMS (Average) Power Handling</b> <sup>1</sup>	400W	400W	LF: 700W, MF/HF: 350W (Bi-amp mode)	800W	2200W
<b>Peak Power Handling</b>	1600W	1600W	LF: 2800W, MF/HF: 1400W (Bi-amp mode)	3200W	8800W
<b>Frequency Range (-10 dB)</b> <sup>2</sup>	55 Hz-20 kHz	60 Hz-20 kHz	70 Hz – 20kHz	37 Hz-300 Hz	28 Hz-125 Hz
<b>Nominal Impedance</b>	8 ohms	16 ohms	8 ohms	4 ohms	4 ohms
<b>Crossover Modes</b>	Passive	Passive	Bi-amp / Tri-amp	Passive	Passive
<b>On-axis Sensitivity 1 W/ 1 m</b>	96 dB SPL	93 dB SPL	106 dB SPL	98 dB SPL	103 dB SPL
<b>Rated Maximum Peak SPL at 1 m</b> <sup>3</sup>	128 dB	125 dB	140 dB	132 dB	143 dB
<b>HF Horn Coverage Angles (-6dB)</b>	110° x 50°	80° x 80°	40° x 30°	-----	-----
<b>Enclosure Material</b>	Birch Plywood				
<b>Color</b>	Black / ISO-flex paint				
<b>Rigging points</b>	5 x M10 threaded hardware	5 x M10 threaded hardware	20 x M10 threaded hardware	14 x M10 threaded hardware Ground Stackable	20 x M10 threaded hardware Ground Stackable
<b>Transducers/Replacement Parts</b>	LF: 1 x 10P/ GM-10P HF: M-60N / GM-M60N	LF: 2 x 6P/ 6P HF: M-34 / GM M-34	LF: 1 x 15GNR/ GM-15G MF: 8AN / GM-8AN HF: M75N / GM-M75N	LF: 2 x 12P/ GM-12P	LF: 2 x 18UXN/ GM-18UXN
<b>Connectors</b>	2 x NL4 Speakon	2 x NL4 Speakon	2 x NL8 Speakon	2 x NL4 Speakon	2 x NL4 Speakon
<b>Dimensions (H x W x D)</b>	60.5 x 29 x 34.5 cm 23.8 x 11.4 x 13.6 in	54.5 x 19.5 x 25.5 cm 21.4 x 7.7 x 10 in	98 x 61 x 58.5 cm 38.6 x 24 x 23 in	35.5 x 70 x 68.5 cm 14 x 27.6 x 27 in	51.4 x 95.2 x 101 cm 20.1 x 37.4 x 39.7 in
<b>Weight</b>	11 kg 24.2 lb	9 kg 19.8 lb	76 kg 167 lb	42.5 kg 93.5 lb	87 kg 191.4 lb
<b>Accessories</b>	ANL-2 AX-SPG1 AX-SPG2 AXC-AT AXW-3 AXF-AR510 AXU-AR510 AXR-AR5	ANL-2 AX-SPG1 AX-SPG2 AXC-AT AXW-1 AXU-AR526 AXR-AR5	ANL-2 ANL-5 AX-SF2158 AX-SF2 AX-SF3	ANL-2 AX-AR3 JP-320	ANL-2 PL-UX218S

- Notes: 1. Based on a 2 hour test continuously applying 6 dB crest factor pink noise.  
2. In Bi-amp mode, with recommended active settings.  
3. Maximum calculated Peak SPL based on sensitivity and RMS power handling.

## INSTALLATION

### Connectors

The **DAS SF series** is designed to facilitate the connection for installations, so it has been provided with two types of connectors: the NL4 type (NL8 in *SF-158*) is standard for professional audio equipment. These terminals are connected in parallel, so that we can carry the amplified audio signal up to a device and we can forward it to the next box, very easily. The polarity of the connectors and other important information for proper connection is indicated on the labels.

Switch to operating mode:  
**BI-AMPLIFIED - TRI-AMPLIFIED**

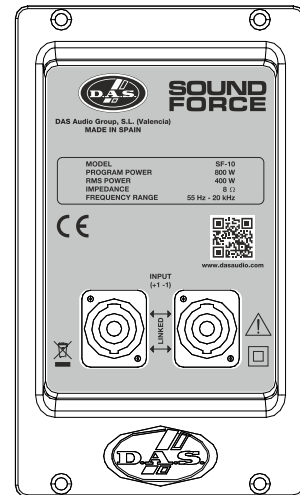
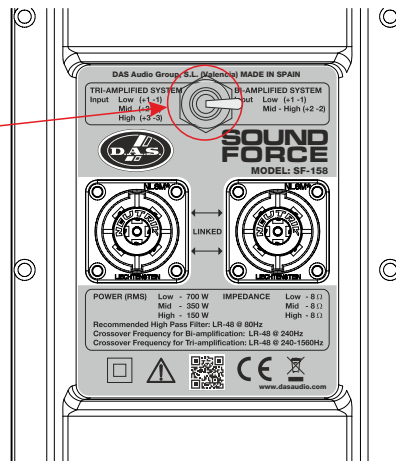
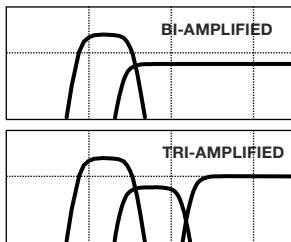

Rest of models with NL4  
**(+1 -1)**

### Rotatable horns

When we install the equipment horizontally, it is advisable to rotate the horn to maintain coverage ranges. In the *SF-10* model, the horn can be rotated: remove the grille, unscrew the horn and turn it 90°, screw the horn and grille back in place. The model *SF-158* has been equipped with a modular set of two horns that can be rotated at the same time, as shown in the following figures:

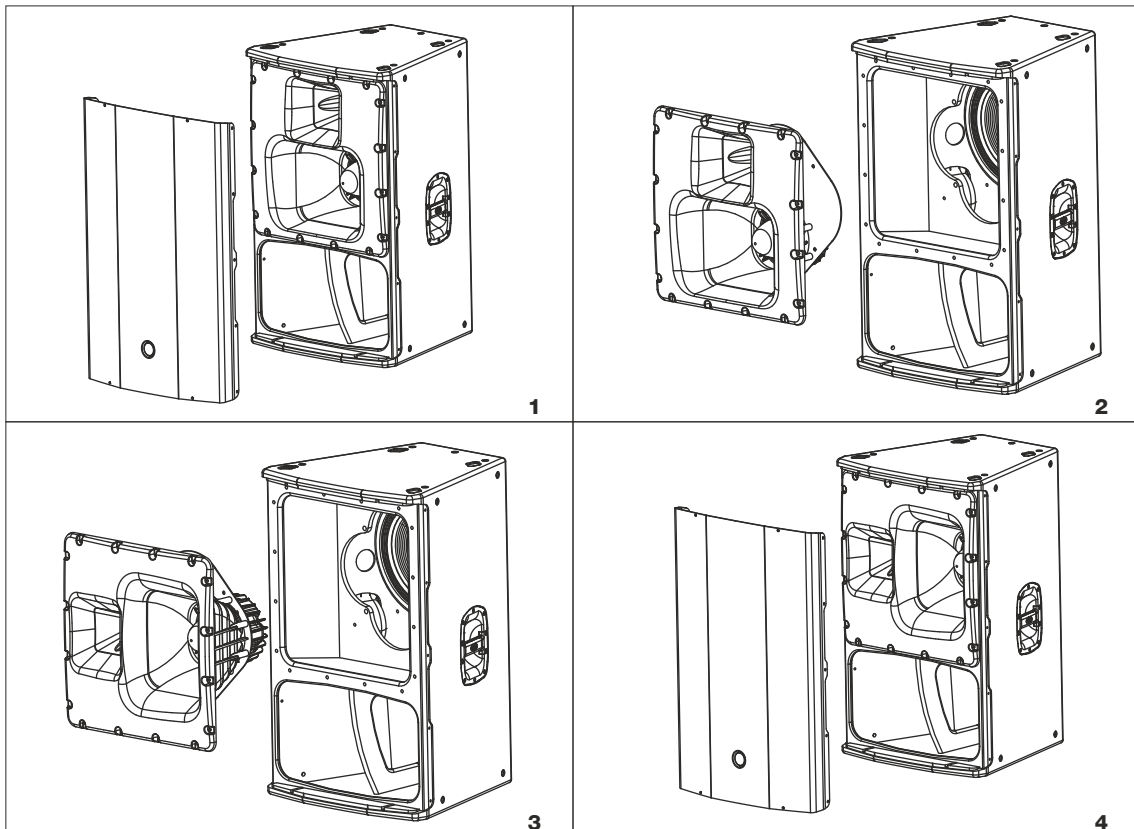

## Coverages

The *SF-10*, *SF-26* and *SF-158* models are designed with trapezoid enclosures to very easily achieve the desired coverages in fixed installations. Next, we show the horizontal coverage with three units of *SF-158*, as example (enclosures seen from above) :

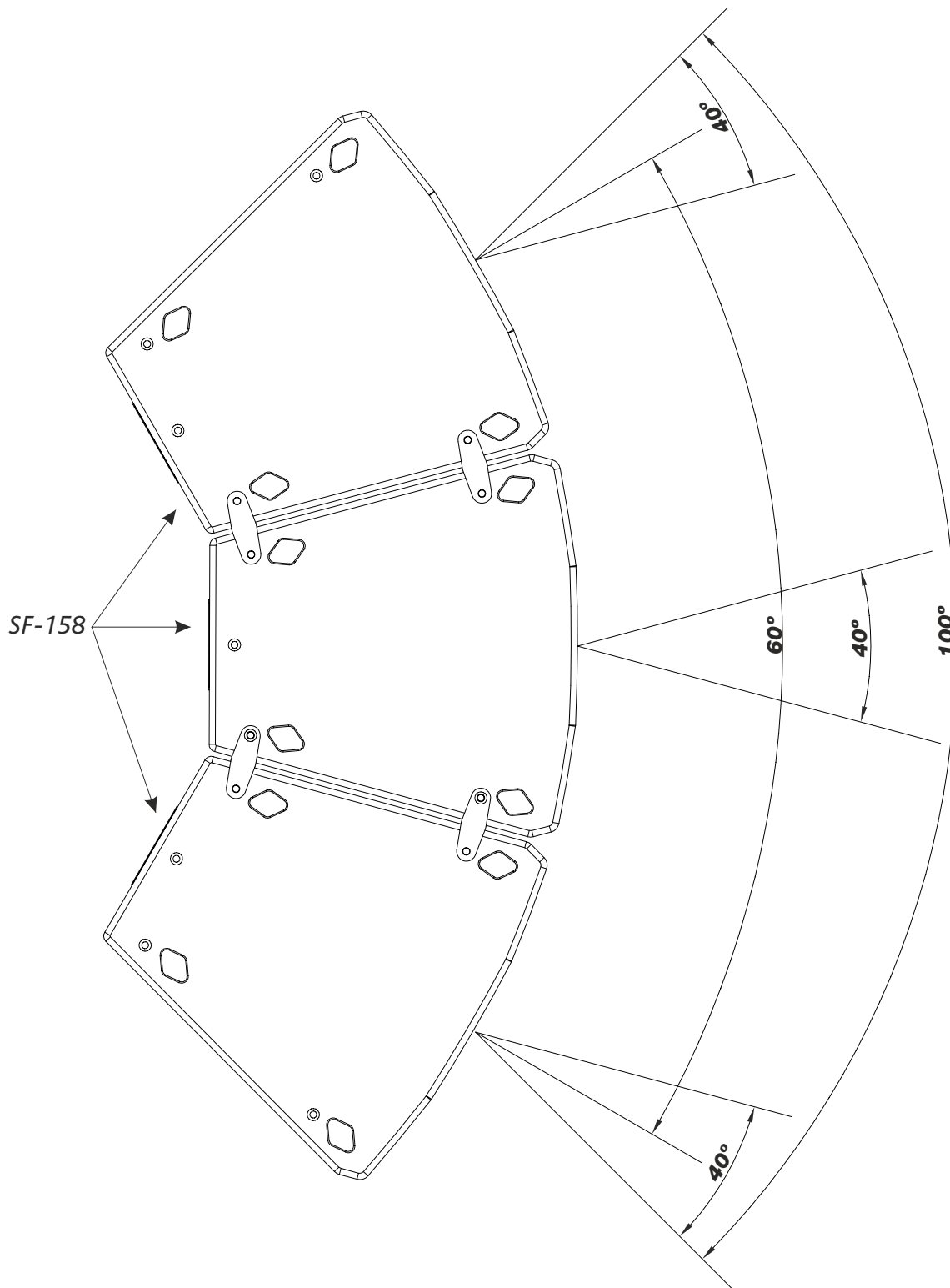

As examples, next, you will see three coverages with *Sound Force series* models.

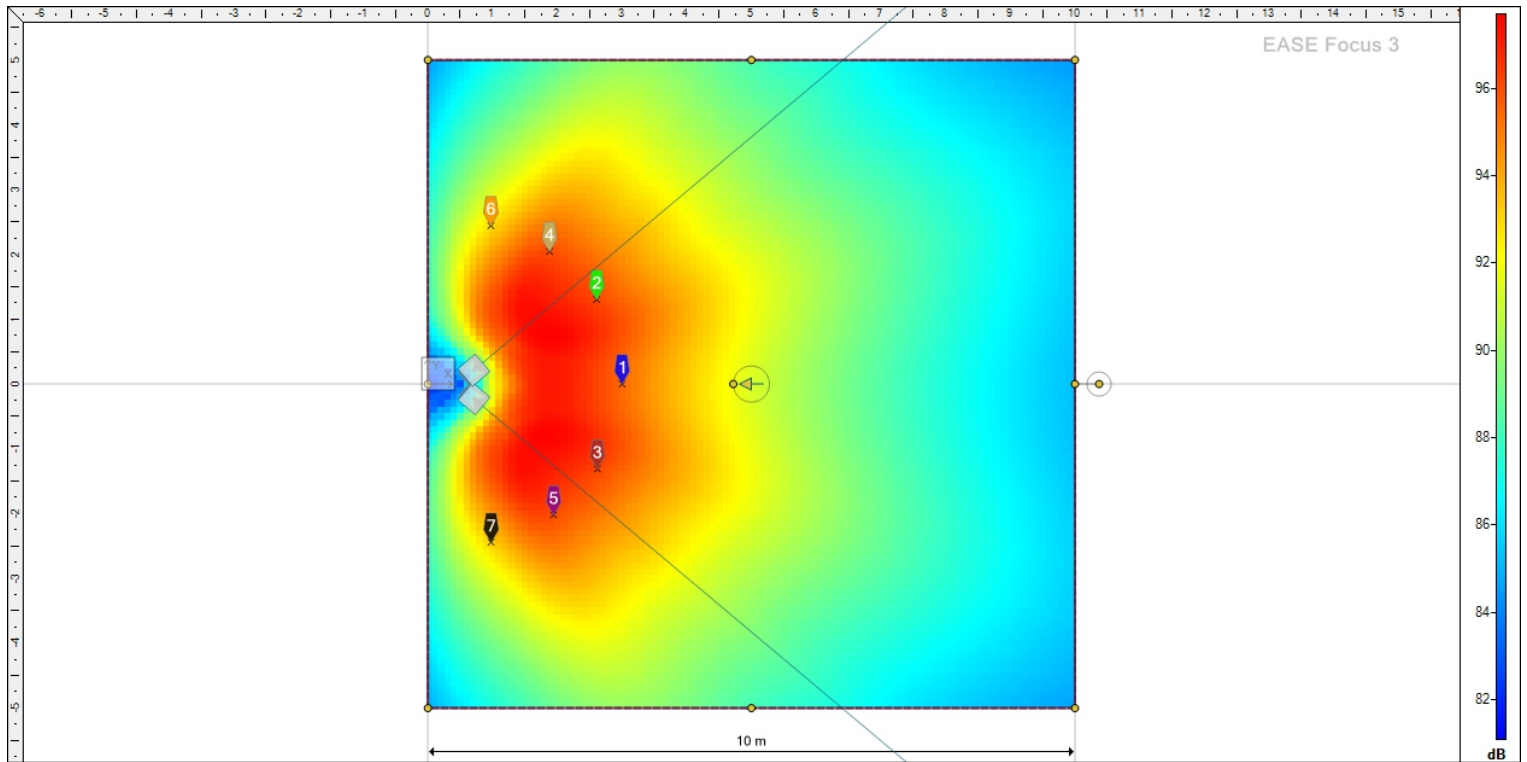

Angle between *SF-10*: 80° (separate cabinets at the front 40cm)  
 Total Horizontal Coverage angle: 160°  
 Shown SPL Map at 4kHz

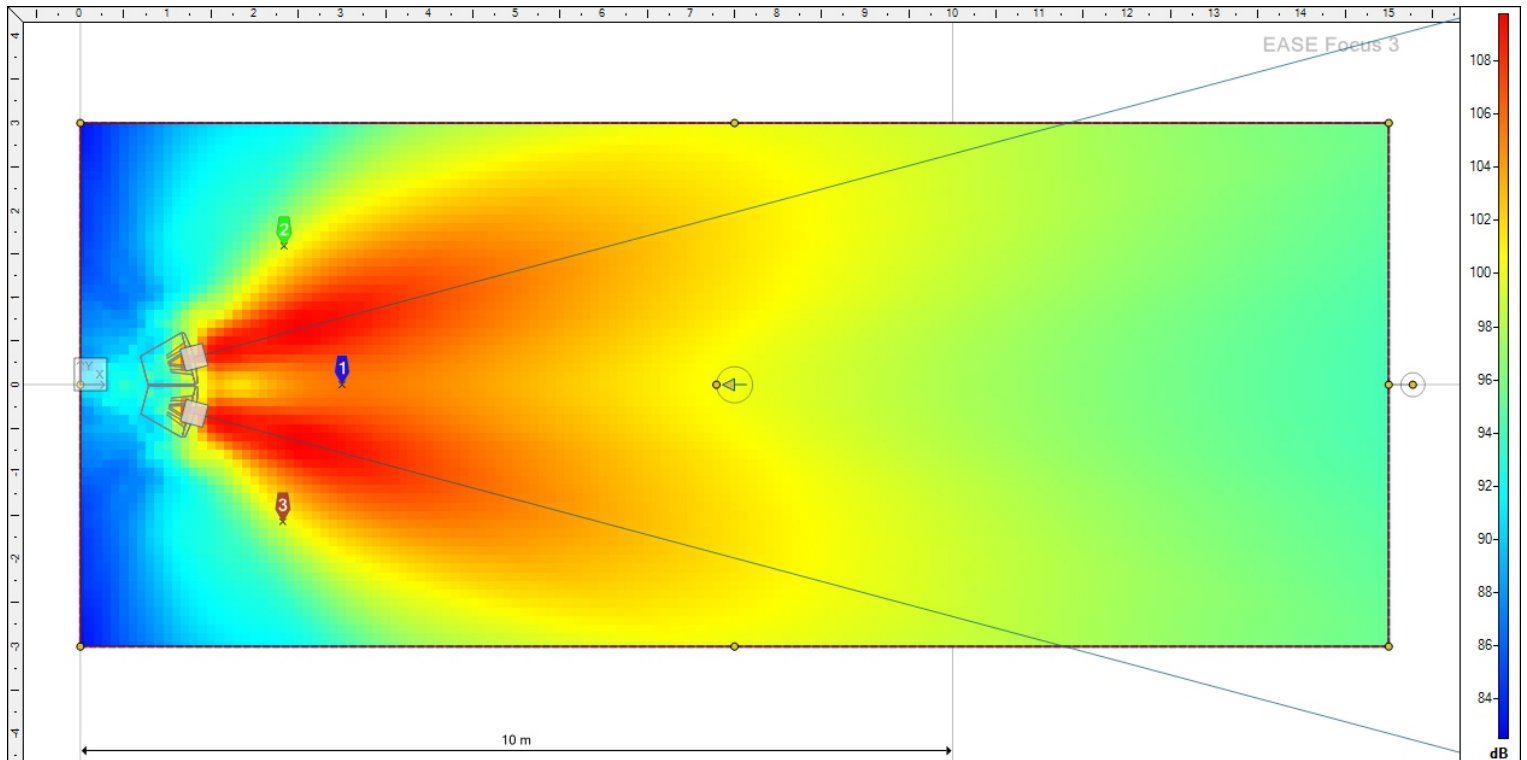

Angle between *SF-158*: 30° (side to side)  
 Total Horizontal Coverage angle: 90°  
 Shown SPL Map at 4kHz



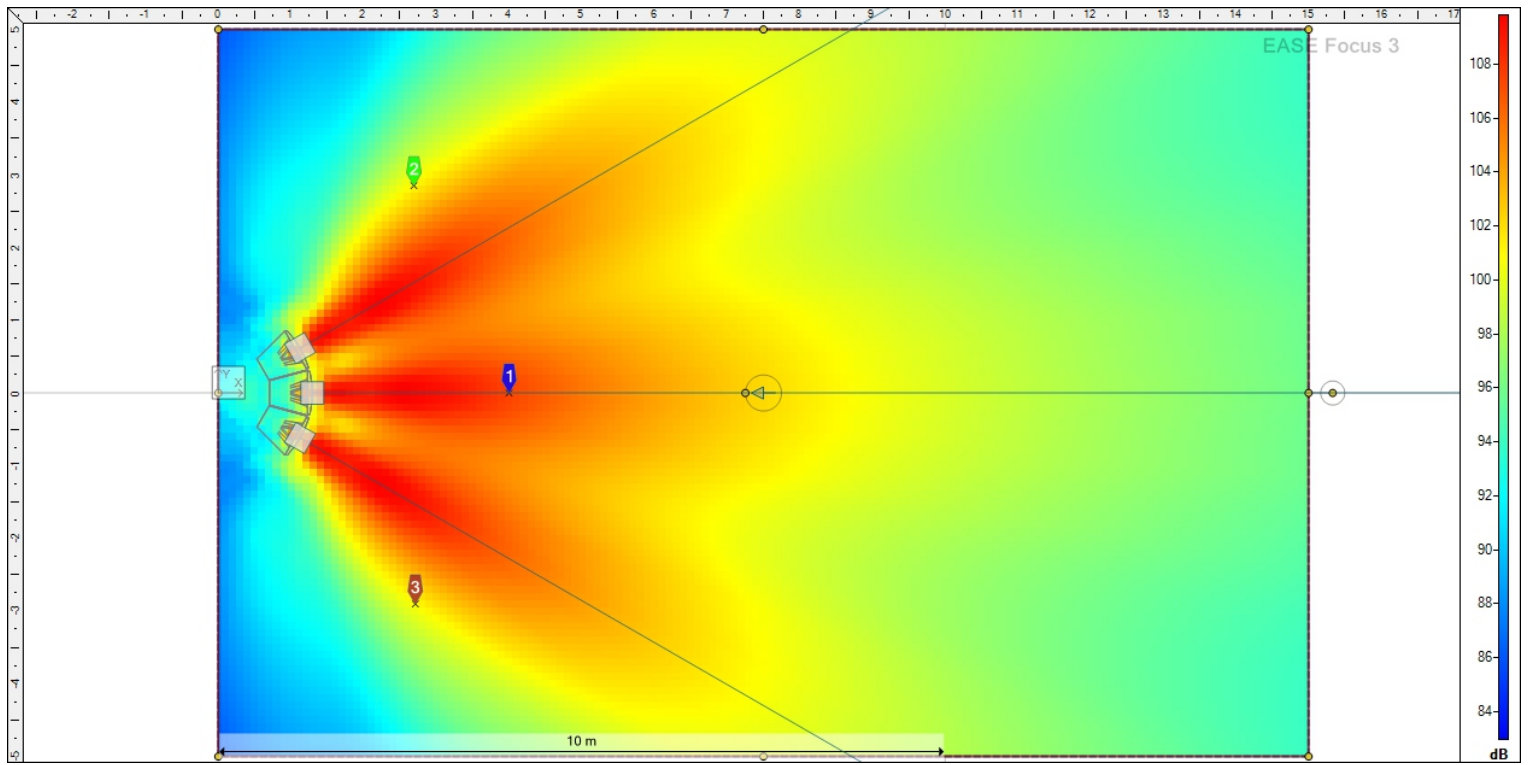

Angle between *SF-158*: 30° (side to side)  
 Total Horizontal Coverage angle: 100°  
 Shown SPL Map at 4kHz

Note: This example as shown on page 15.

## ACCESSORIES

To perform any operations related to flying the system, read the present document first, and act on the warnings and advice given.

The goal is to allow the user to become familiar with the mechanical elements required to fly the acoustic system, as well as the safety measures to be taken during set-up and teardown.

Only experienced installers with adequate knowledge of the equipment and local safety regulations should fly speaker boxes.

It is the user's responsibility to ensure that the systems to be flown (including flying accessories) comply with state and local regulations.

The working load limits in this manual are the results of tests by independent laboratories. It is the user's responsibility to stay within safe limits. It is the user's responsibility to follow and comply with safety factors, resistance values, periodical supervisions and warnings given in this manual.

Product improvement by means of research and development is on going at DAS Specifications are subject to change without notice.

It is common practice to apply 5:1 safety factors for enclosures and static elements.

For slings and elements exposed to material fatigue due to friction and load variation the following ratios must be met; 5:1 for steel cable slings, 4:1 for steel chain slings and 7:1 polyester slings.

Thus, an element with a breaking load limit of 1000 kg may be statically loaded with 200 kg (5:1 safety factor) and dynamically loaded with 142 Kg (7:1 safety factor).

The load capacity, of each lift motor, should be correspond to a safety factor of 10:1.

When flying a system, the working load must be lower than the resistance of each individual flying point in the enclosure, as well as each box.

Hanging hardware should be regularly inspected and suspect units replaced if in doubt.

This is important to avoid injury and absolutely no risks should be taken in this respect. It is highly recommended that you implement an inspection and maintenance program on flying elements, including reports to be filled out by the personnel that will carry out the inspections.

Local regulations may exist that, in case of accident, may require you to present evidence of inspection reports and corrective actions after defects were found.

### **Absolutely no risks should be taken with regards to public safety.**

When flying enclosures from ceiling support structures, extreme care should be taken to assure the load bearing capabilities of the structures so that the installation is absolutely safe.

Do not fly enclosures from unsafe structures.

Consult a certified professional if needed.

All flying accessories that are not supplied by DAS Audio are the user's responsibility. Use at your own risk.

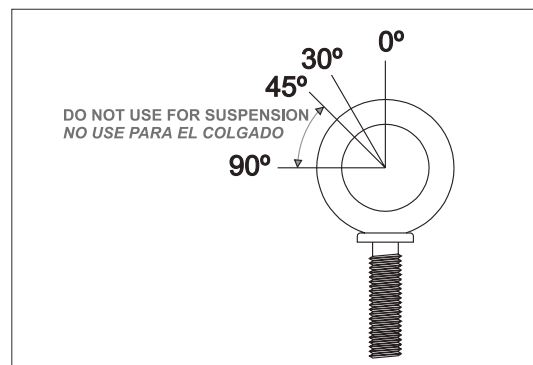
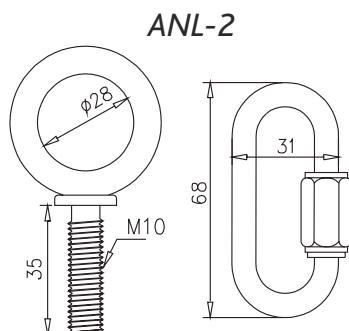

	0 Degrees	30 Degrees	45 Degrees	More than 45 Degrees
% Working Load	100%	65%	30%	25%

To hang the units, the Allen-head screws must be removed and replaced by M10 eyebolts on one side of the enclosure. Each rigging point has 200 kg (440 lb) working load limit.

Then choose the slings or chains of required load resistance and length, bearing in mind that the length difference between the front and back slings or chains will determine the vertical orientation. Alternatively, the back bottom eyebolt points can be used to provide vertical orientation.

The *ANL-2* set is an optional set of four eyebolts and four carabiners. (Dimensions are in millimetres).

Each *ANL-2* eyebolt has a rated working load of 200 kg. (440 lb). Each *ANL-2* carabiner has a working load of 330 kg (726 lb). If using other hardware, make sure it is rated to handle the required load.

When using eyebolts it is important to bear in mind that the rated working load is only true for a load applied in the plane of the eye, and is significantly reduced for other angles. The drawing illustrates the concept.

The table shows the variation of the working load as a function of the load angle. In the case of the *ANL-2* eyebolt, this means that the 200 kg working load becomes 60 kg at 45 degrees. Do not use eyebolt flying if the load angle is higher than 45 degrees.

**Note: As always, when we handle heavy loads, we should wear appropriate clothing and protective elements such as gloves, safety shoes, etc.**

Next, you will see some examples, both horizontal and vertical array.

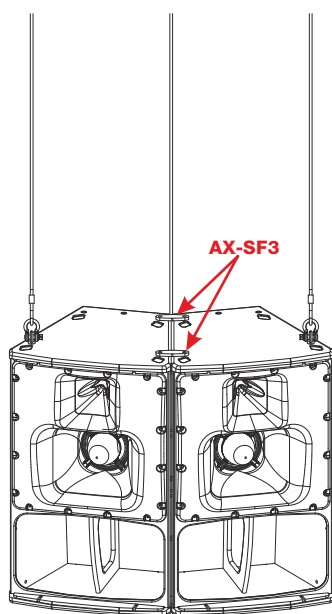

**Frontal view**

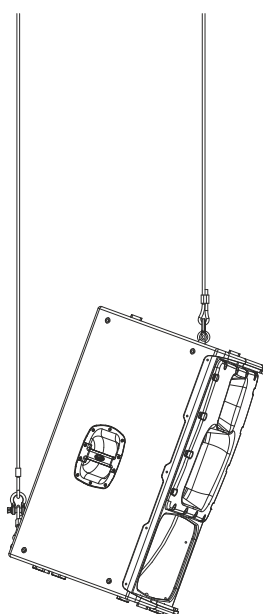

**Side view**

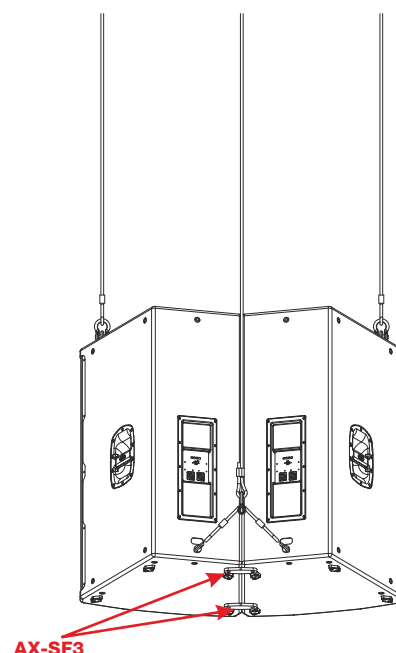

**Rear view**

## Horizontal Array

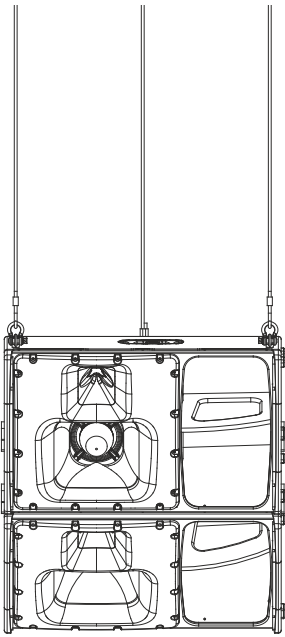

**Frontal view**

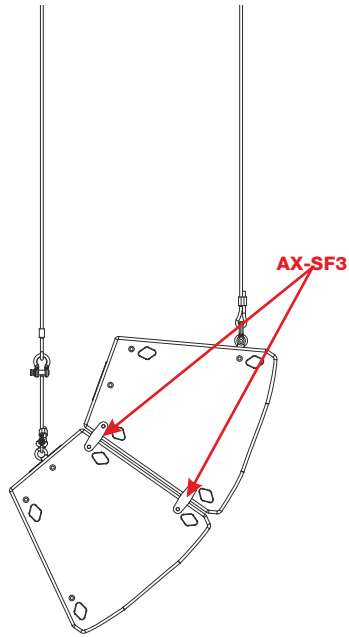

**Side view**

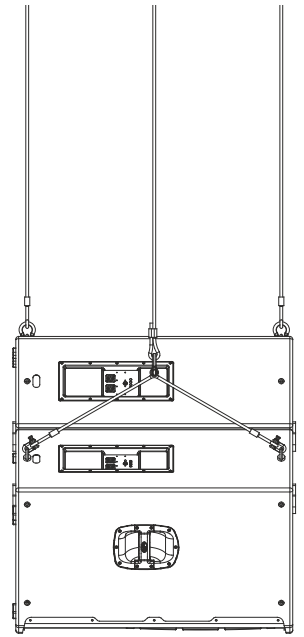

**Rear view**

## Vertical Array

### Stacked Systems

However, the most common will be the stacking systems. Below is an example (2x SF-158 upon 2x SF-221), step by step.

First, we will stack 2x SF-221 as shown below, joining the boxes with 4x AX-SF2.

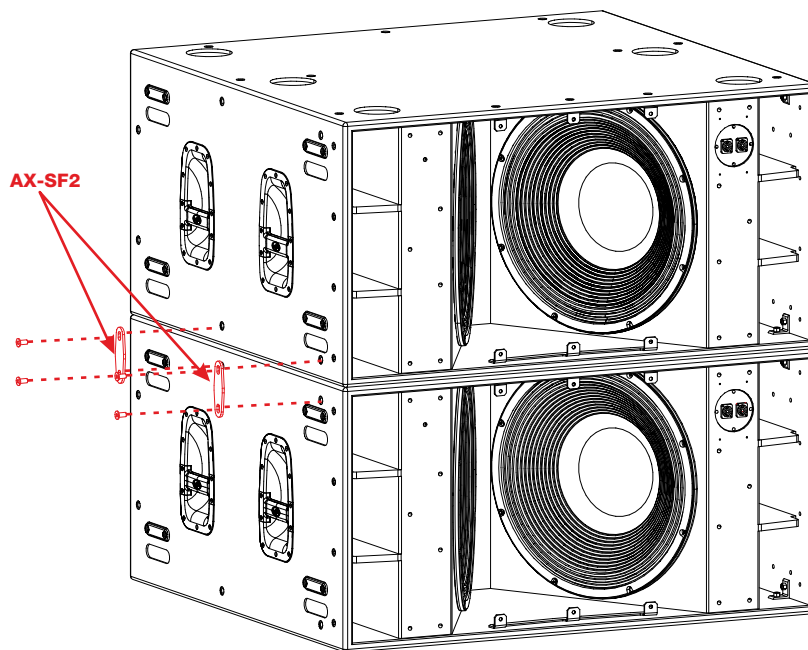

Now, we will screw the AX-SF2158 over them.

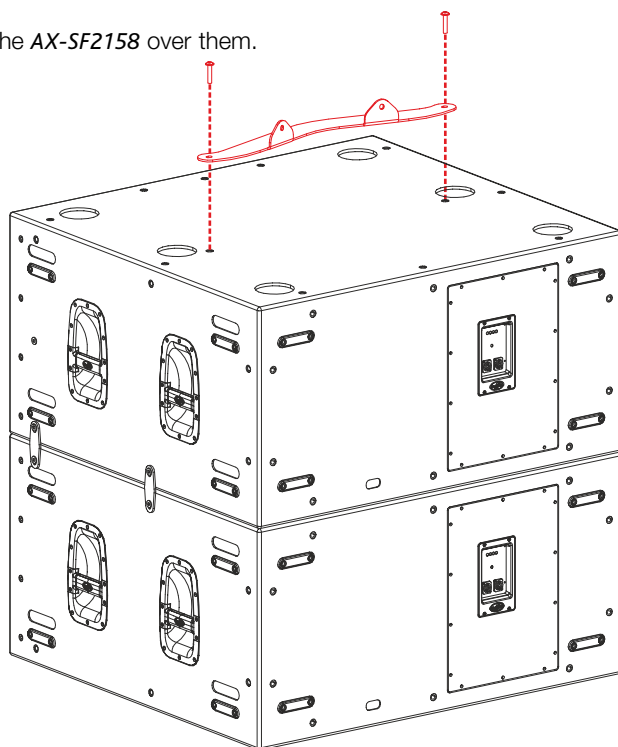

Next, we will screw 2x SF-158 to the AX-SF2158.

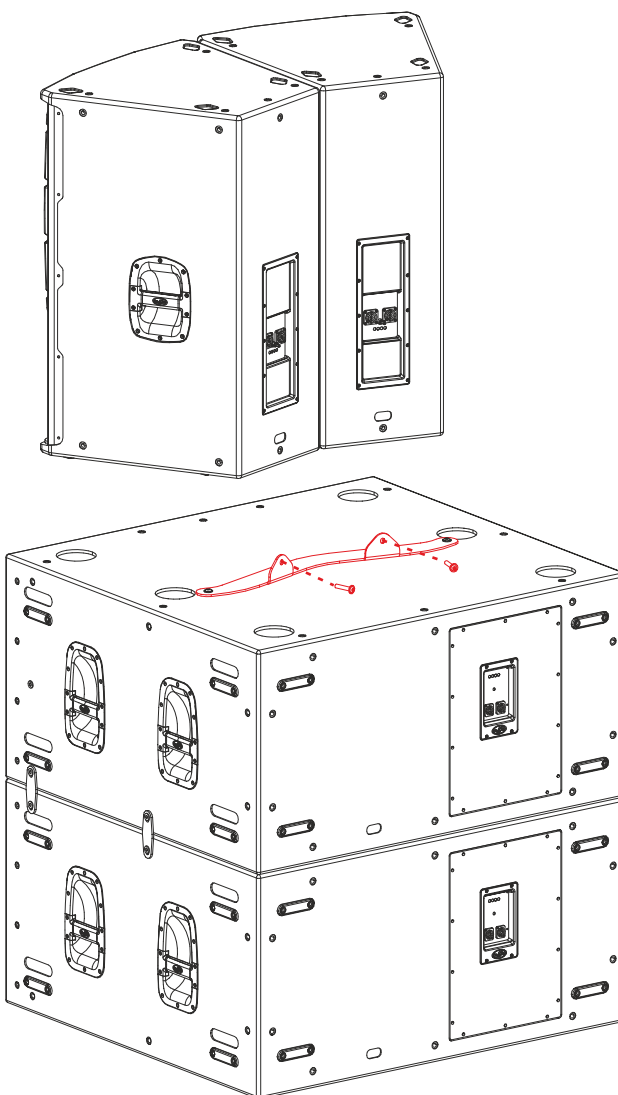

Finally, we will join the *SF-158* units with 2x *AX-SF2*.

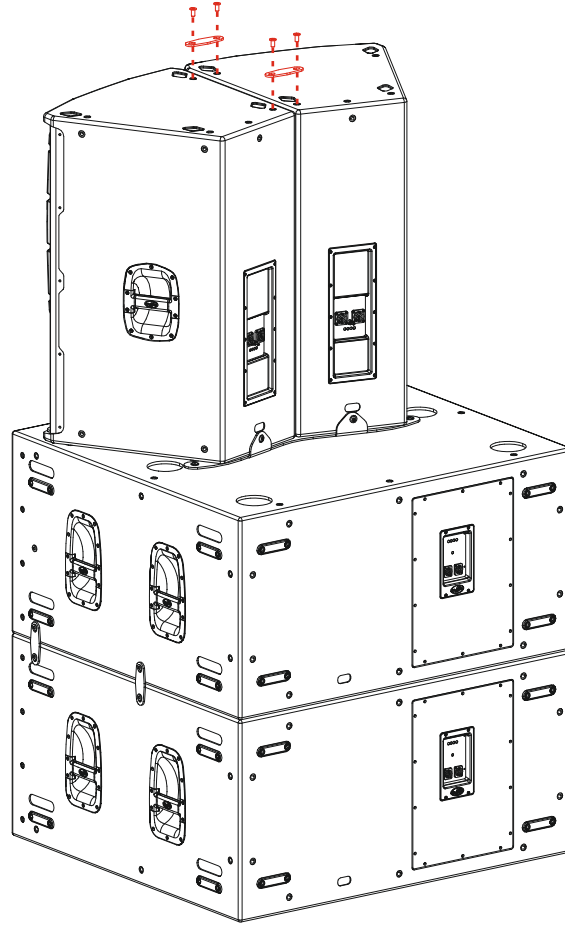

As can be seen, the result is a solid stacked system.

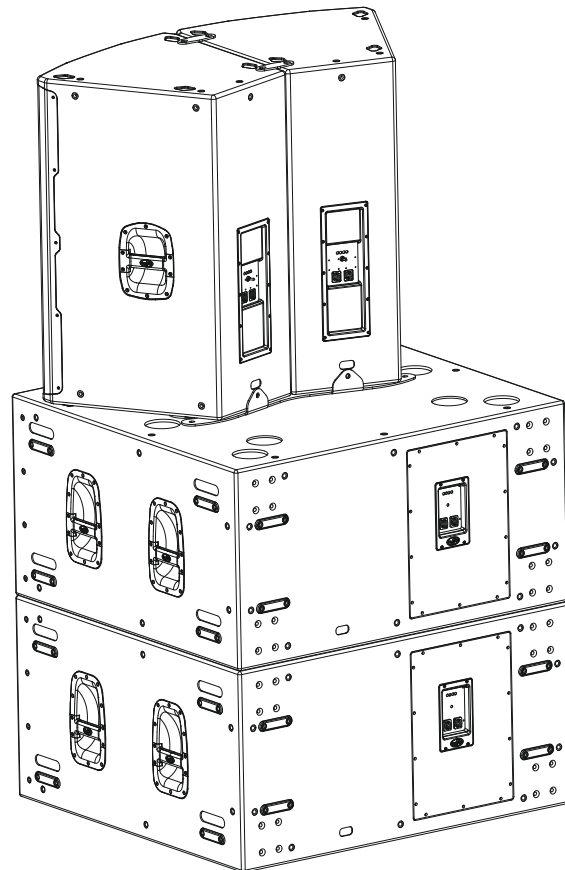

## ANNEX : Table for cable selection

This table shows the power loss in % and dB, for different cable lengths and sections shown. It is recommended that the losses do not exceed 30% in any case (around 3dB). Although it is recommended minimizing losses, the maximum acceptable losses are usually around 15% (approximately 1.4dB).

Longitud / Length		Calibre	Area	R	Perdida de potencia / Power Loss			
m	ft	AWG	mm2	Ohms	% @ 8 ohms	% @ 4 ohms	dB @ 8 ohms	dB @ 4 ohms
5	16,4	18	0,8	0,2250	2,74	5,33	-0,241	-0,475
		16	1,31	0,1374	1,69	3,32	-0,148	-0,293
		14	2,1	0,0857	1,06	2,10	-0,093	-0,184
		12	3,3	0,0545	0,68	1,35	-0,059	-0,118
		10	5,3	0,0340	0,42	0,84	-0,037	-0,073
		8	8,35	0,0216	0,27	0,54	-0,023	-0,047
10	33	18	0,8	0,4500	5,33	10,11	-0,475	-0,926
		16	1,31	0,2748	3,32	6,43	-0,293	-0,577
		14	2,1	0,1714	2,10	4,11	-0,184	-0,364
		12	3,3	0,1091	1,35	2,65	-0,118	-0,234
		10	5,3	0,0679	0,84	1,67	-0,073	-0,146
		8	8,35	0,0431	0,54	1,07	-0,047	-0,093
15	49	18	0,8	0,6750	7,78	14,44	-0,704	-1,354
		16	1,31	0,4122	4,90	9,34	-0,436	-0,852
		14	2,1	0,2571	3,11	6,04	-0,275	-0,541
		12	3,3	0,1636	2,00	3,93	-0,176	-0,348
		10	5,3	0,1019	1,26	2,48	-0,110	-0,218
		8	8,35	0,0647	0,80	1,59	-0,070	-0,139
25	82	18	0,8	1,1250	12,33	21,95	-1,143	-2,153
		16	1,31	0,6870	7,91	14,66	-0,716	-1,377
		14	2,1	0,4286	5,08	9,68	-0,453	-0,884
		12	3,3	0,2727	3,30	6,38	-0,291	-0,573
		10	5,3	0,1698	2,08	4,07	-0,182	-0,361
		8	8,35	0,1078	1,33	2,62	-0,116	-0,231
50	164	18	0,8	2,2500	21,95	36,00	-2,153	-3,876
		16	1,31	1,3740	14,66	25,57	-1,377	-2,565
		14	2,1	0,8571	9,68	17,65	-0,884	-1,686
		12	3,3	0,5455	6,38	12,00	-0,573	-1,110
		10	5,3	0,3396	4,07	7,83	-0,361	-0,708
		8	8,35	0,2156	2,62	5,11	-0,231	-0,456
75	246	18	0,8	3,3750	29,67	45,76	-3,057	-5,314
		16	1,31	2,0611	20,49	34,01	-1,991	-3,610
		14	2,1	1,2857	13,85	24,32	-1,295	-2,421
		12	3,3	0,8182	9,28	16,98	-0,846	-1,616
		10	5,3	0,5094	5,99	11,30	-0,536	-1,041
		8	8,35	0,3234	3,88	7,48	-0,344	-0,675
100	328	18	0,8	4,5000	36,00	52,94	-3,876	-6,547
		16	1,31	2,7481	25,57	40,72	-2,565	-4,542
		14	2,1	1,7143	17,65	30,00	-1,686	-3,098
		12	3,3	1,0909	12,00	21,43	-1,110	-2,095
		10	5,3	0,6792	7,83	14,52	-0,708	-1,362
		8	8,35	0,4311	5,11	9,73	-0,456	-0,889



[www.dasaudio.com](http://www.dasaudio.com)

UM\_SF3\_01\_EN

**DAS Audio Group, S.L.**  
C/. Islas Baleares, 24  
46988 Fuente del Jarro  
Valencia, SPAIN  
Tel. +34 96 134 0860

**DAS Audio of America, INC.**  
6900 NW 52th Street  
Miami, FL. 33166 - U.S.A.  
TOLL FREE: 1 888 DAS 4 USA

**DAS Audio Asia PTE. LTD.**  
3 Temasek Avenue, Centennial  
Tower #34-36  
Singapore 039190  
Tel. +65 6549 7760

**DAS do Brasil LTDA.**  
Rua Dos Andradas, 382 SL  
Santa Efigênia, São Paulo  
Brasil. CEP: 01208-000  
Tel. +551133330764