

Quadratt 1U

Quad attenuator, attenuverter, mixer and DC voltage source

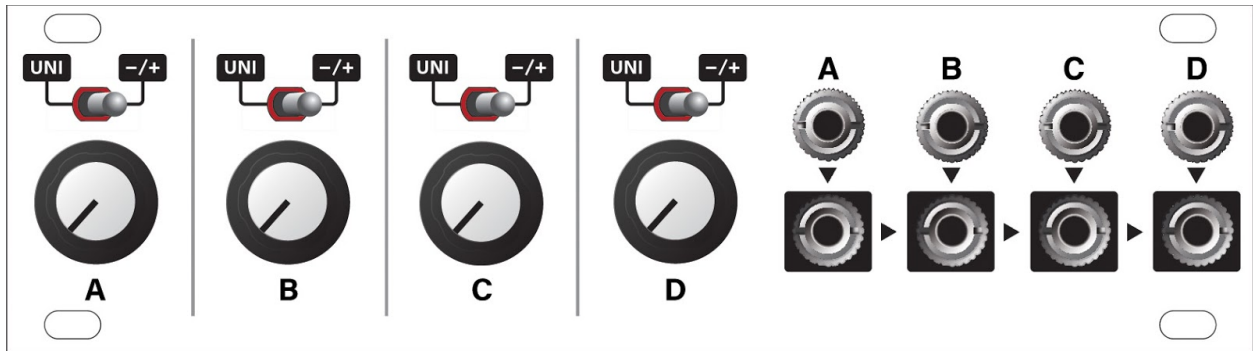

Table of Contents

[Table of Contents](#)

[Compliance](#)

[Installation](#)

[Before Your Start](#)

[Installing Your Module](#)

[Overview](#)

[Usage Examples](#)

[Front Panel](#)

[Controls](#)

[Inputs & Outputs](#)

[Technical Specifications](#)

Compliance



This device complies with Part 15 of the FCC Rules. Operation is subject to the following two conditions: (1) this device may not cause harmful interference, and (2) this device must accept any interference received, including interference that may cause undesired operation.

Changes or modifications not expressly approved by Intellijel Designs, Inc. could void the user's authority to operate the equipment.

Any digital equipment has been tested and found to comply with the limits for a Class A digital device, pursuant to part 15 of the FCC Rules. These limits are designed to provide reasonable protection against harmful interference when the equipment is operated in a commercial environment. This equipment generates, uses, and can radiate radio frequency energy and, if not installed and used in accordance with the instruction manual, may cause harmful interference to radio communications.



This device meets the requirements of the following standards and directives:

EMC: 2014/30/EU

EN55032:2015 ; EN55103-2:2009 (EN55024) ; EN61000-3-2 ; EN61000-3-3

Low Voltage: 2014/35/EU

EN 60065:2002+A1:2006+A11:2008+A2:2010+A12:2011

RoHS2: 2011/65/EU

WEEE: 2012/19/EU

Installation

This module is designed for use within an Intellijel-standard 1U row, such as contained within the Intellijel 4U and 7U Eurorack cases. Intellijel's 1U specification is derived from the Eurorack mechanical specification set by Doepfer that is designed to support the use of lipped rails within industry standard rack heights.

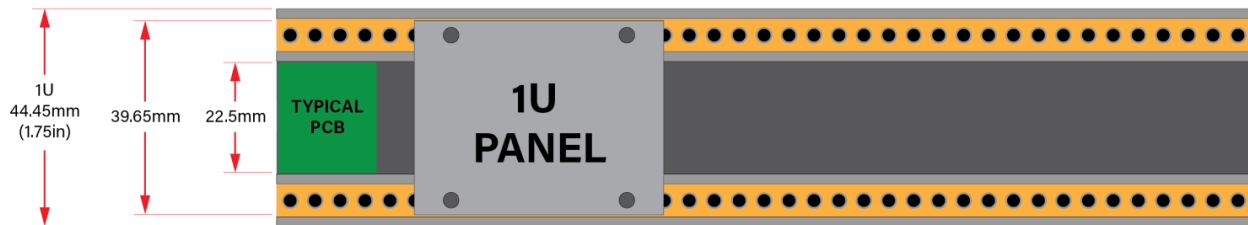
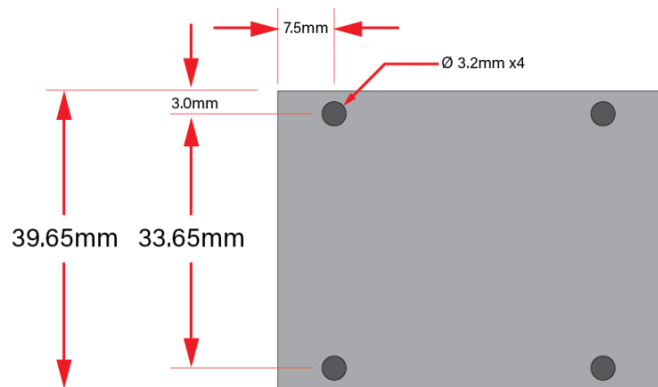

Before Your Start

Intellijel Eurorack modules are designed to be used with a Eurorack-compatible case and power supply. We recommend you use Intellijel cases and power supplies.

Before installing a new module in your case, you must ensure your power supply has a free power header and sufficient available capacity to power the module:

- Sum up the specified +12V current draw for all modules, including the new one. Do the same for the -12 V and +5V current draw. The current draw will be specified in the manufacturer's technical specifications for each module.
- Compare each of the sums to specifications for your case's power supply.
- Only proceed with installation if none of the values exceeds the power supply's specifications. Otherwise you must remove modules to free up capacity or upgrade your power supply.

You will also need to ensure your case has enough free space (hp) to fit the new module. To prevent screws or other debris from falling into the case and shorting any electrical contacts, not leave gaps between adjacent modules, and cover all unused areas with blank panels. Similarly, do not use open frames or any other enclosure that exposes the backside of any module or the power distribution board.

You can use a tool like [ModularGrid](#) to assist in your planning. Failure to adequately power your modules may result in damage to your modules or power supply. If you are unsure, please [contact us](#) before proceeding.

Installing Your Module

When installing or removing a module from your case always turn off the power to the case and disconnect the power cable. Failure to do so may result in serious injury or equipment damage.

Ensure the 10-pin connector on the power cable is connected correctly to the module before proceeding. The red stripe on the cable must line up with the -12V pins on the module's power connector. Different modules use different ways to indicate the -12V pins. Some may be labelled with "-12V;" a white stripe next to the -12V pins; the words "red stripe;" or some combination of these. Additionally, some modules may have shrouded headers, thus preventing backward connections.

Most modules will come with the cable already connected but it is good to double check the orientation. Be aware that some modules may have headers that serve other purposes so ensure the power cable is connected to the right one.

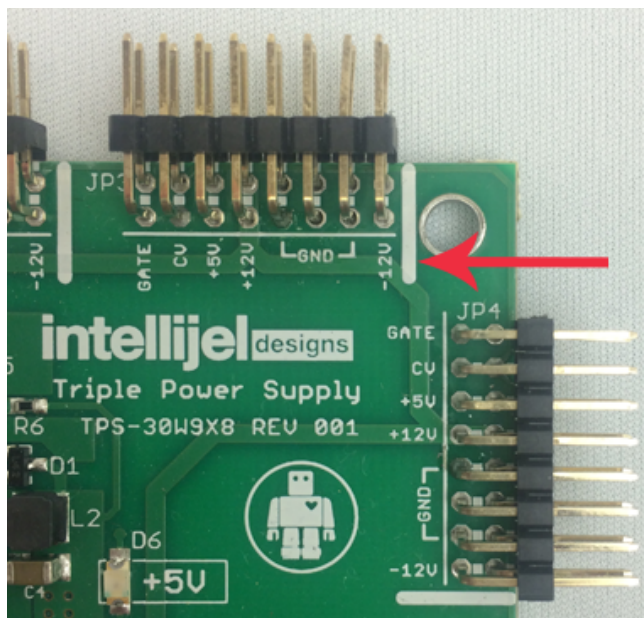
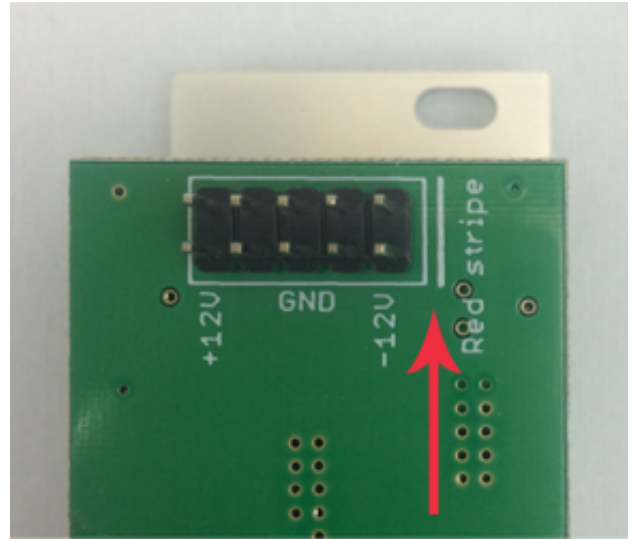

The other end of the cable, with a 16-pin connector, connects to the power bus board of your Eurorack case. Ensure the red stripe on the cable lines up with the -12V pins on the bus board. On Intellijel power supplies the pins are labelled with "-12V" and a thick white stripe.

If you are using another manufacturer's power supply, check their documentation for instructions.

Once connected, the cabling between the module and power supply should resemble the picture below:

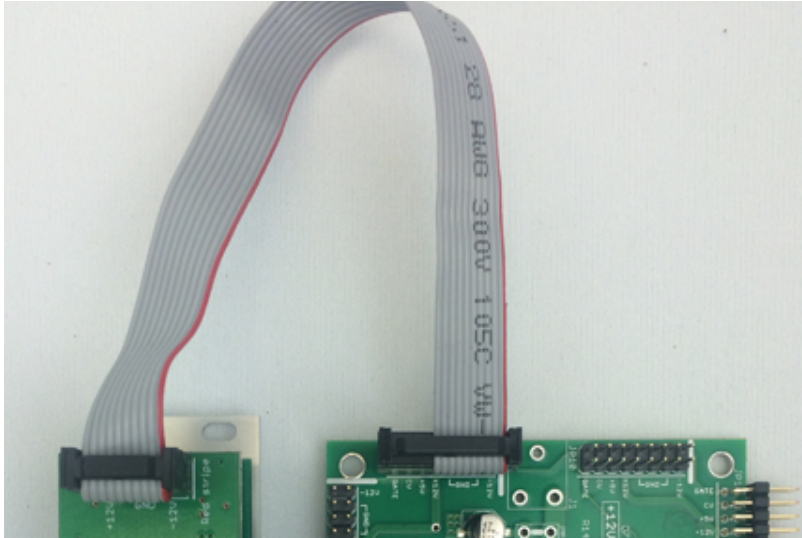

Before reconnecting power and turning on your modular system, double check that the ribbon cable is fully seated on both ends and that all the pins are correctly aligned. If the pins are misaligned in any direction or the ribbon is backwards you can cause damage to your module, power supply, or other modules.

After you have confirmed all the connections, you can reconnect the power cable and turn on your modular system. You should immediately check that all your modules have powered on and are functioning correctly. If you notice any anomalies, turn your system off right away and check your cabling again for mistakes.

After you have confirmed all the connections, you can reconnect the power cable and turn on

Overview

Quadratt is a four channel active/buffered attenuverter and summing mixer. Each channel has a knob, which can function as a unipolar attenuator or a bipolar attenuverter, depending on the setting of its corresponding two-position switch.

Each input is normalled to a precision +5V DC voltage source. With nothing plugged into the jacks, each knob controls a voltage range of 0 -to- +5V or -5V -to- +5V depending on the position of the mode switch.

Each output is normalled to mix into the output of the channel to its right making it possible to do sub mixes in groups of 2, 3 or all four channels.

NOTE: Earlier versions of Quadratt had a different type of physical switch and slightly different labelling, but are otherwise identical to the version illustrated and described by this manual.

Usage Examples

This humble collection of simple parameters provides a wealth of useful functions to the modular synthesist. Here are some basic examples of how you might employ Quadratt in your patches:

- **Attenuation:** Assume you want to *subtly* modulate filter resonance, but your filter of choice doesn't have a built-in attenuator on its resonance CV input. If you were to plug the output of an LFO directly into the resonance CV input on your filter, you'd be modulating it at full amplitude — meaning your LFO would cycle the resonance from “none” to “ear shattering squelch” and back again. But what if you just want resonance to undulate a little bit? Quadratt to the rescue!

Plug the output of your LFO into the Quadratt's **IN A**, then plug **OUT A** into your filter's resonance CV jack. You'll now be able to “dial down” the peak-to-peak amplitude of the LFO using the Quadratt's corresponding attenuator knob.

- **Inversion:** Assume you want to control a module with an envelope. Normally, voltage increases during the attack section of an ADSR, then decreases during the decay or release segment. But what if you want the inverse? What if you want some sonic attribute to get *more* pronounced as the signal decays, not less? For this you need to invert the envelope. Once again, Quadratt to the rescue!

Plug the output of your envelope into Quadratt's **IN A**, set Channel A's polarity switch to **-+**, then turn its attenuator knob *counterclockwise* past 12:00 — an inverted envelope now appears at Quadratt's **OUT A**.

- **Voltage Offsets:** Assume you have a Sample & Hold module sending random notes to an oscillator, only you want to constrain that unruly 10+ octave range of notes to just one or two octaves in the bass range. One way to do this is to use two channels of a Quadratt.

Plug your S&H output into Quadratt's **IN B**; connect **OUT B** to your oscillator's pitch input; then use the Channel B attenuator to limit the range of notes to an octave or two. Next, use Quadratt's Channel A (into which nothing is connected) to negatively offset the note range down into the bass frequencies. Do this by setting Channel A's polarity switch to **-/+**, then turning the corresponding attenuator knob *counterclockwise* past 12:00. Because nothing is plugged into Quadratt's **OUT A**, **OUT B** contains a sum of Channels A and B, giving you both the reduced note range and the lower frequencies you desire.

- **CV Mixing:** What if you want to modulate some parameter with more than one control voltage at a time? Perhaps you want to send a square wave to modulate a filter's cutoff frequency giving it a steady "pulsing" sound while simultaneously sweeping it with a slow, triangular LFO so that the pulsing sound rises and falls over time. Again, Quadratt is on the case. And, once again, you'll be using two channels.

Plug the square wave output of the "pulsing" LFO into Quadratt's **IN A** and connect **OUT B** to your filter's frequency CV input. Use Channel A's attenuverter to set the amount of pulse you want to hear. Next, plug the triangle wave output of the "slow sweeping" LFO into Quadratt's **IN B**. **OUT B** now contains of sum of Quadratt's A and B channels. Use Channel B's attenuverter to set how much the pulse sweeps up and down the frequency band. You now have two different CV sources controlling one destination.

- **Audio Mixing:** Audio is a voltage too. So you're probably asking yourself, "can I use Quadratt to mix multiple channels of *audio* together as well?" Yes, you can!

Set all of Quadratt's polarity switches to **UNI** and turn all its knobs fully *counterclockwise*. Plug the output of one oscillator in **IN A**, another into **IN B**, and so on. Plug only **OUT D** into your audio amplifier, leaving **OUTS A-C** unconnected. Rotate Channel A's attenuator clockwise and you'll hear the oscillator connected to **IN A**. Turn Channel B, C and D's attenuators clockwise to add their corresponding inputs to the mix.

Front Panel

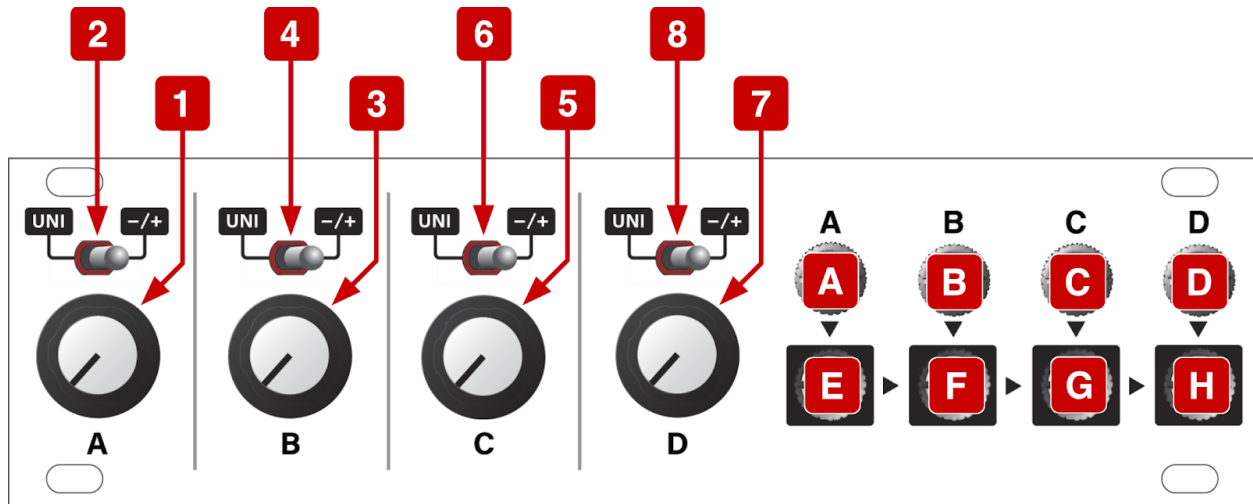

Controls

1. Channel A attenuator

Attenuates the voltage level present at IN A. The behaviour of the knob depends on the position of the corresponding polarity switch. The attenuation amount is linear.

2. Channel A polarity switch

This is a 2-position switch that sets the polarity of the OUT A signal.

UNI: With the switch in the left **UNI** position, the channel functions as a standard attenuator. The full value of the channel's input voltage is passed through to the output when the attenuator knob is fully *clockwise*. None of the input voltage passes through to the output when the attenuator knob is fully *counterclockwise*; and half the voltage passes through to the output when the knob is at the *12:00* (straight up) position.

-/+: With the switch in the right **-/+** position, the channel acts as a bipolar attenuverter. The full value of the channel's input voltage is passed through to the output when the attenuator knob is fully *clockwise*. The inverse of the input voltage is sent to the output when the knob is fully *counterclockwise*; and none of the input voltage passes through to the output when the knob is at the *12:00* (straight up) position.

3. Channel B attenuator

Behaves the same as the Channel A attenuator but for channel B.

4. Channel B polarity switch

Behaves the same as the Channel A polarity switch but for channel B.

5. Channel C attenuator

Behaves the same as the Channel A attenuator but for channel C.

6. Channel C polarity switch

Behaves the same as the Channel A polarity switch but for channel C.

7. Channel D attenuator

Behaves the same as the Channel A attenuator but for channel D.

8. Channel D polarity switch

Behaves the same as the Channel A polarity switch but for channel D.

Inputs & Outputs

A. IN A

Input for channel A.

With no cable plugged in, Quadratt sends a 5V DC voltage into Channel A, which you can attenuate (or invert) with the Channel A attenuator knob. For example, with nothing plugged into Channel A and the Channel A knob fully clockwise, 5V is sent out channel A. If the Channel A knob is fully counterclockwise and its polarity switch is set to **UNI**, then 0V is sent out Channel A. If the Channel A knob is fully counterclockwise and its polarity switch is set to **-/+**, then -5V is sent out Channel A.

B. IN B

Input for channel B. With no cable plugged in, Quadratt sends 5V into Channel B, which you can attenuate (or invert) with the Channel B attenuator knob.

C. IN C

Input for channel C. With no cable plugged in, Quadratt sends 5V into Channel C, which you can attenuate (or invert) with the Channel C attenuator knob.

D. IN D

Input for channel D. With no cable plugged in, Quadratt sends 5V into Channel D, which you can attenuate (or invert) with the Channel D attenuator knob.

E. OUT A

Output for channel A, which is the attenuverted value of IN A.

F. OUT B

Output for channel B, which is the attenuverted value of IN B. With no cable connected to OUT A, this jack outputs the sum of channels A and B.

G. OUT C

Output for channel C, which is the attenuverted value of IN C. With no cable connected to OUT A or OUT B, this jack outputs the sum of channels A, B and C. Plugging a cable into OUT A removes it from OUT C, meaning $OUT\ C = OUT\ B + OUT\ C$. Plugging a cable into OUT B removes both OUT A and OUT B from OUT C.

H. OUT D

Output for channel D, which is the attenuverted value of IN D. With no cable connected to OUTS A, B or C, this jack outputs the sum of channels A through D. Plugging a cable into OUT A removes it from OUT D, meaning $OUT\ D = OUTS\ B + C + D$. Plugging a cable into OUT B removes both OUT A and OUT B from OUT D, meaning $OUT\ D = OUT\ C + D$. Plugging a cable into OUT C removes OUTS A through C from OUT D.

Technical Specifications

Width	28 hp
Maximum Depth	25 mm
Current Draw	24 mA @ +12V 23 mA @ -12V