



# VENTIS 112

Passive Reinforcement Speaker

## APPLICATIONS

- Band P.A.
- Personal monitor
- Small theatres
- Auditoriums
- Piano bar
- DJ
- Stage monitor
- Conference rooms
- Fixed installations in live clubs
- Pubs
- Gyms

## KEY FEATURES

- 2-way passive sound reinforcement speaker
- 400W RMS recommended amplifier
- 0,59" birch plywood scratch resistant enclosure
- Rotatable horn
- Built-in passive crossover
- Control panel features 2 x Speakon NL-4 IN&LINK
- Completely manufactured in Italy



## PRODUCT DESCRIPTION

The FBT VENTIS 112 has been designed to meet the highest standards in both performance and aesthetic appeal. The FBT VENTIS are as suitable for fixed installation, portable use, as they are for use on the stage. The FBT VENTIS 112 incorporating a 12" LF woofer with 2.5" voice coil, custom made for FBT and 1" exit throat B&C HF compression driver with 1.4" voice coil; a fully rotatable constant directivity horn ensure accurate coverage (80° H x 50° V). With a frequency range from 55Hz to 18kHz the FBT VENTIS 112 speaker provide high fidelity sound for both speech and music applications with a maximum SPL of 129dB. Ideal for small fixed installations the FBT VENTIS 112 speaker system have an impedance of 8 Ohm and the internal crossover is at a fixed frequency of 1.6kHz. Constructed in 0,59" birch plywood, the FBT VENTIS 112 has two aluminium handle. Rear panel connections feature 2 x NL4 Neutrik Speakon. The optional mounting bracket allow the FBT VENTIS 112 speaker to be surface mounted on walls or ceilings.

## ELECTRICAL SPECIFICATIONS

System Type	2 Way
Recommended amplifier	400W RMS
Long term power *	200W
Short term power (IEC 268-5)**	800W
Nominal impedance	8 Ohm
Frequency Response	55Hz - 18kHz (@ -6dB)
Sensitivity	98dB (@ 1W / 1mt)
Maximum SPL cont/peak	125 / 129dB
Dispersion	80°H x 50°V rotatable
Crossover frequency	1.6kHz
Recommended HP filter	45Hz / 24dB oct

## PHYSICAL SPECIFICATIONS

Low Frequency Woofer	12" / 2.5" coil
High Frequency Driver	1" / 1.4" coil
Input Connectors	2 x Speakon
Net Dimensions (WxHxD) inch	15.25 x 25.59 x 14.96
mm	387.5 x 650 x 380
Net Weight	20.1kg / 44.31lb
Enclosure Material	0.59" birch plywood

\* 100 hour power test, IEC-268-5 standard (display the long term RMS voltage handling, using IEC filtered 6dB crest factor pink noise).

\*\* Based on peak level of 6dB crest factor random noise signal used for test.



# VENTIS 112

## DIMENSIONAL DRAWINGS

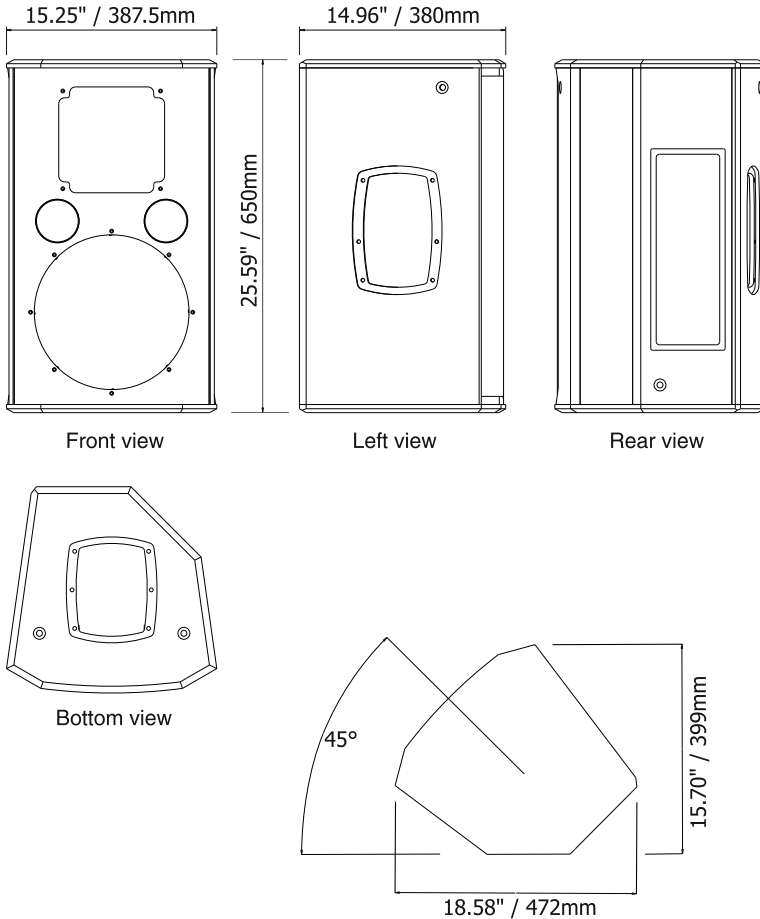

## CONTROL PANEL

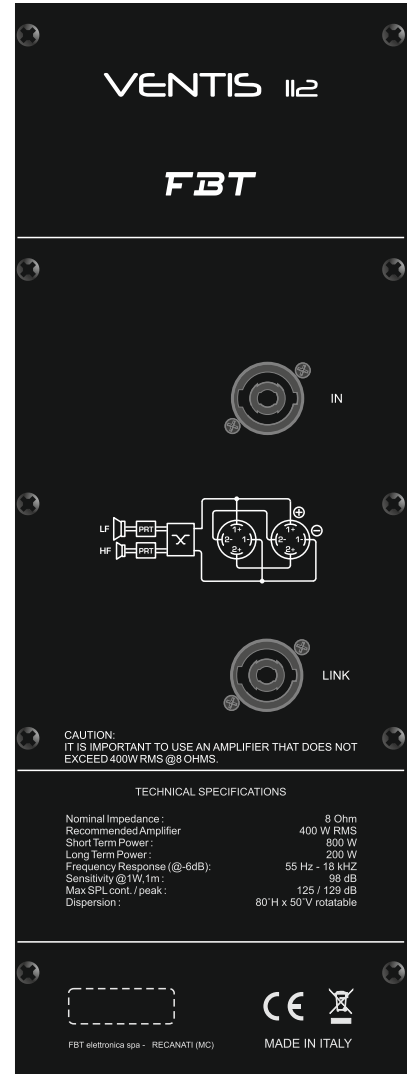

## ACCESSORIES

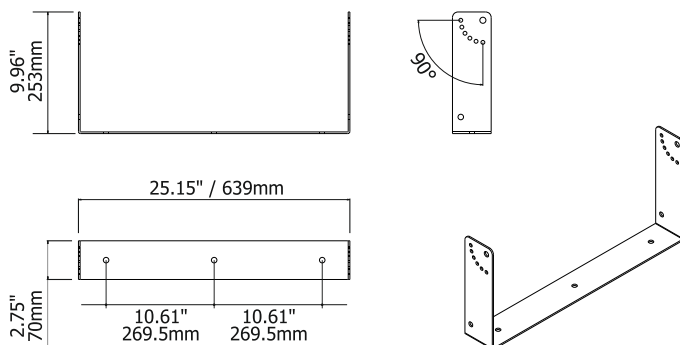

### Caution.

This FBT loudspeaker should be suspended overhead only in accordance with the procedures and limitations specified in the user's manual. This system should be suspended in compliance with local and state overhead suspension ordinances. The VENTIS speakers use only with FBT mount for wall installation.