

# IRIDIUM

— amp & ir cab —

USER MANUAL

**strymon**<sup>®</sup>

## Table of Contents

Connecting Iridium .....	3
Controls and Connections .....	6
Live Edit Functions .....	13
Power Up Modes .....	15
External Control .....	18
MIDI Functionality .....	23
Factory Reset .....	31
Features .....	32
Specifications .....	33
Appendices	
Live Edit and Power Up Quick Reference .....	35
IR Cab Details .....	39
Audio Routing .....	43
Sample Settings .....	47
Warranty .....	49

## Connecting Iridium

Iridium delivers responsive tube amp tones, ultra-high quality impulse response speaker cabinets, and natural sounding room ambience. It shines as the centerpiece of many different playing applications.

### 1 ON STAGE

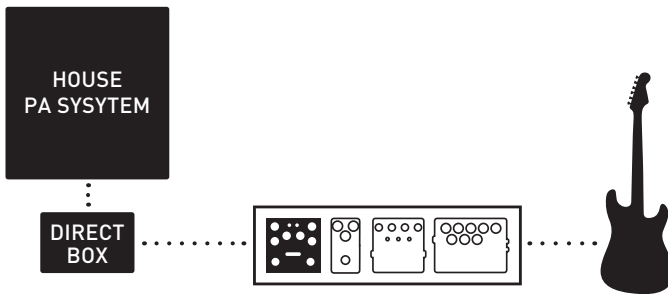

Connect a pedalboard containing Iridium to a house PA system for excellent repeatable tone, control, and flexibility in a live situation. Monitor through the house monitoring system or in-ear monitors. For a dedicated personal on-stage monitor, connect your pedalboard to a powered full-range speaker.

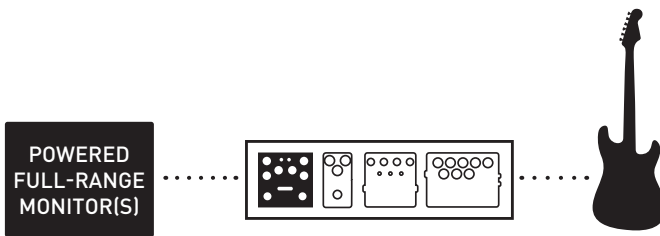

**NOTE:** Because the purpose of Iridium is to deliver amp and cab tones, it is not desirable to enable Iridium in front of a guitar amp. If you use the same pedalboard both with an amp and in direct situations, simply bypass Iridium when using your board with an amp.

## Connecting Iridium (cont.)

### 2 IN THE STUDIO

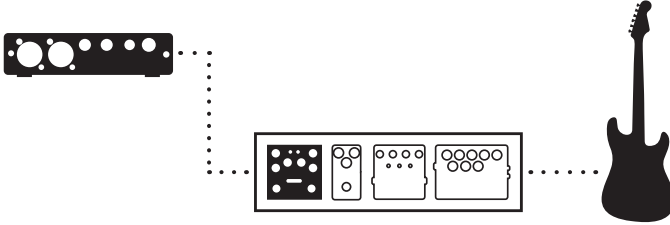

Connect Iridium directly to a recording interface for great guitar tone instantly without the need to set up an amp or microphones.

---

### 3 AT HOME

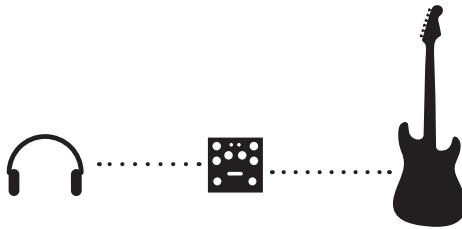

Connect headphones directly to Iridium to experience immersive classic amp tones in a natural sounding room without an amp.

---

## ADDITIONAL TIPS FOR STAGE, STUDIO, AND HOME

Iridium can be used on its own or as part of a pedalboard.

- Place Iridium at the end of your signal chain to capture the sound of the entire pedalboard connected to the front of an amp.
- Place Iridium before time-based effects for a different tonal character if you prefer.
- Use headphones to check out a pedalboard that normally connects to an amp by connecting its output(s) to Iridium.

## Connecting Iridium (cont.)

### 4 OTHER WAYS TO USE IRIDIUM

Iridium also allows for specialized use cases.

#### Amp processing without IR cabs

Select Iridium's Cab Bypass mode and connect the output(s) to the effects return or power amp input on a guitar amp.

*(See [page 15](#) for Cab Bypass mode configuration details.)*

#### IR cab processing without amps

Select Iridium's Amp Bypass mode and connect a preamp or preamp pedal (such as Riverside) to Iridium's input.

*(See [page 15](#) for Amp Bypass mode configuration details.)*

**WARNING:** *Never connect the Speaker Output of a guitar amplifier to Iridium!* If you wish to use Iridium's IR cabs with a guitar amp, you can either use a line out from the amp or the amp's effects send. Note that you will still need to connect a load to the speaker output with either of these options. You may also need to set Iridium to Line input level.

*(See [page 16](#) for Input level configuration details.)*

#### Non-cab WAV files

It is possible to load any 24bit/96kHz WAV impulse response into Iridium, including impulses of bass cabs, acoustic instrument body resonance, samples of music, etc.

## Controls and Connections - Front Panel

### AMP

Selects one of three different amp types.

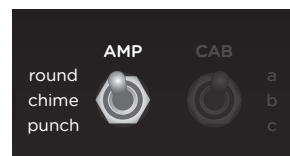

#### round

Based on\* a **Fender® Deluxe Reverb®**, this amp is clean, bright, and mid-scooped, with plenty of headroom. While preserving access to all the tones originally available from the Deluxe's Normal channel, our amp gives you something extra: a midrange control. With the **MIDDLE** knob at noon, you get the original fixed-resistor value and standard tonal characteristics of the Deluxe. Turn down the **MIDDLE** control for a more scooped sound, or turn it up for tweed-era tones.

#### chime

Based on\* the Brilliant channel of a **Vox® AC30TB**, this amp is jangly and bright, providing air for subtle passages with a light touch, and bite when you want to dig in. The **MIDDLE** knob acts a tone cut knob, providing high-end roll-off just before the power tubes, per the AC30TB design. In addition to the full available gain of the original amp, toward the top end of the **DRIVE** knob's range of travel, we've added a frequency-shaped front end boost to tighten the low end while driving the amp further into saturation.

#### punch

Based on\* a **Marshall® Plexi** (Super Lead model number 1959), this powerful amp is meatier, with higher gain than the other two amps, and has a powerful midrange response. This amp features a buttery, smooth overdrive. Setting the **DRIVE** control at around 2 o'clock gets you the maximum gain the original Plexi design allowed. Turn the **DRIVE** beyond 2 o'clock to access custom hot-rodged Plexi high gain tones.

\*All product names are trademarks of their respective owners, which are in no way associated or affiliated with Strymon. These product names, descriptions and images are provided for the sole purpose of identifying the specific products that were studied during Strymon's sound design process. See [page 34](#) for a list of U.S. registered trademarks.

## Controls and Connections - Front Panel

### CAB

The CAB switch selects one of three speaker cabinet options for each amp type. Each cab is made up of left and right 24 bit/96 kHz 500ms impulse responses. Mono cabs have the same IR loaded into both sides.

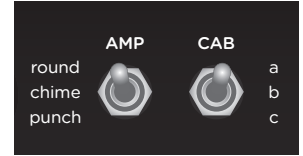

Iridium is pre-loaded with a curated set of 9 speaker cabinet IRs from top IR vendors Cabir.eu, Celestion®, OwnHammer, and Valhallir.at.

The factory installed IRs are based on\* the following:

#### round

- a: 1x12 Fender® Deluxe Reverb®
- b: 1x12 Fender® Blues Junior®
- c: 2x10 Fender® Vibrolux®

#### chime

- a: 2x12 Vox® AC30-6 open back fawn
- b: 1x12 Custom cab w/ Celestion® Blue AlNiCo
- c: 4x12 Mesa/Boogie® Half-Back®

#### punch

- a: 4x12 Marshall® w/ Celestion® G12M-25s
- b: 2x12 Custom cab w/ Celestion® Vintage 30s
- c: 8x12 Marshall® w/ Celestion® T652s

A more complete description of these IRs and the original speaker cabinets can be found on [Appendix 2](#). Additionally, the factory installed IRs can be replaced with any 24 bit/96 kHz WAV format IRs using our free Strymon Impulse Manager software available at [strymon.net/support/iridium](http://strymon.net/support/iridium).

\*All product names are trademarks of their respective owners, which are in no way associated or affiliated with Strymon. These product names, descriptions and images are provided for the sole purpose of identifying the specific products that were studied during Strymon's sound design process. See [page 34](#) for a list of U.S. registered trademarks.

## Controls and Connections - Front Panel (cont.)

### DRIVE

Adjusts the amount of gain applied to the incoming signal, controlling both the analog JFET input stage and the preamp gain of the selected amp. As the **DRIVE** amount is increased, the **LEVEL** knob is compensated allowing the gain to increase while the output level remains the same.



### LEVEL

Controls the output volume when the pedal is ON. Controls the left and right outputs as well as the headphone output.

**NOTE:** For a better listening experience, we have included a LEVEL TRIM Live Edit function that allows for the overall output volume from both the **OUT L** and **OUT R** outputs along with the headphone output to be compensated without affecting the leveling between your saved presets. This is a useful way to adjust the level when using headphones.

*(See [page 14](#) for details.)*



## Controls and Connections - Front Panel (cont.)

Each tone knob on a classic amplifier controls a potentiometer that interacts with the other components that make up the tone stack, creating a complex, interdependent frequency response. Our Matrix Modeling™ process captures all these subtleties, faithfully delivering the unique tonal qualities of each amp type.

### MIDDLE

Adjusts the tone stack of the **round** and **punch** amp types to highlight the middle frequencies.

Rolls off high frequencies as the knob is turned up for the **chime** amp type.

### TREBLE

Adjusts the tone stack of the selected amp type to highlight the high frequencies.



### BASS

Adjusts the tone stack of the selected amp type to highlight the low frequencies.

### ROOM

Controls the level of natural room ambience, placing your amp and cab in a natural sounding room by combining 256ms impulse responses of real rooms with algorithmic reverb for extended decay. *The IR portion of the hybrid rooms is not replaceable.*

(See [page 13](#) for details about adjusting the Room Size.)

## Controls and Connections - Front Panel (cont.)



### FAV .....

Recalls a stored Favorite setting. Includes all knob and switch settings. To save a new Favorite setting, press and hold **FAV** until the **FAV** LED blinks **BLUE**. Then, press **FAV** again to save a the new Favorite setting.

Favorite presets can also be saved using MultiSwitch Plus or an external MIDI device.

*(See [page 22](#) for details about saving while using MultiSwitch Plus.)*

*(See [page 28](#) about saving while using MIDI.)*

### ON .....

Activates amp, cab, and room processing. LED indicates On/Off state, LED color indicates Output mode.

LED color indicates the selected Output mode. **RED** indicates Normal mode (default).

*(See [page 15](#) for Output mode configuration details.)*

## Controls and Connections - Rear Panel

### Audio Input Selector

**MONO:** Use with a mono input signal such as a guitar. Output is stereo. Use **OUT L** for mono connection.

**STEREO:** Use with a stereo input signal. Output is stereo.

**SUM:** Use with a stereo input signal that you would like to sum to mono. Use **OUT L** for summed output.

*(See [Appendix 3](#) for signal flow illustrations.)*

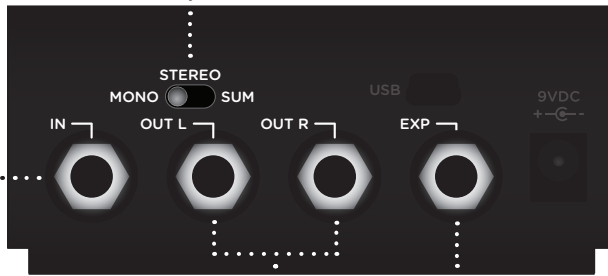

### IN

Stereo high impedance input. Use a standard instrument cable for mono. Use a TRS stereo adapter/cable for stereo input.

*(See [page 16](#) for configuration details.)*

### OUTPUTS

Stereo audio signal outputs. Use **OUT L** for mono.

### EXP

Multifunction communication jack for external control of Iridium's features and functions. Use a standard TRS expression pedal to act as a volume pedal before the amp (default configuration). **EXP** input can also be used to connect a Strymon MultiSwitch Plus, MiniSwitch, or MIDI EXP cable for remote preset selection and MIDI automation.

*(See [page 19](#) for configuration details.)*

## Controls and Connections - Rear Panel (cont.)

### USB

Can be used to load IR files and firmware updates via computer. More information and the latest downloads can be found at: [strymon.net/support/iridium](http://strymon.net/support/iridium)

### POWER

Use the included power supply or an adapter with the following rating:

- 9VDC center negative
- 500mA minimum



## Facing Panel



### HEADPHONE OUT

Stereo 1/8 inch headphone output. Designed to be used with relatively high impedance headphones (between 25 to 70 ohms). **LEVEL** knob adjusts volume.

**NOTE:** The headphone output provides the same signal as the quarter-inch outputs. Using higher impedance headphones will lower the signal level from the headphone output. Use the convenient **LEVEL TRIM** function to adjust the output level without affecting the level saved to a Favorite setting or MIDI preset.

(See [page 14](#) for details.)

## Live Edit Functions - Room Size

Determines the size of the room reverb.

- 1 Press and hold the **ON** footswitch. Once both LEDs flash, release the footswitch.



- 2 Turn the **ROOM** knob to select the size of the Room. **ON** LED indicates status.
  - Small - **GREEN**
  - Medium - **AMBER** (default)
  - Large - **RED**

- 3 Press the **ON** or **FAV** footswitch to exit and store the Room Size setting.

**NOTE:** Room size is saved per Favorite setting or preset.

## Live Edit Functions - Level Trim

Adjusts the output volume without altering the level that is saved to a Favorite setting. This is useful when monitoring with headphones.

- 1 Press and hold the **ON** footswitch. Once both LEDs flash, release the footswitch.



- 2 Turn the **LEVEL** knob to adjust the output level. **FAV** LED indicates status.

Sweeps from -20 dB (**GREEN**) to +3 dB (**AMBER**).

LED turns **RED** when there is no boost or cut of the output level, near the 12 o'clock position.

- 3 Press the **ON** or **FAV** footswitch to exit and store the Level Trim setting.

**NOTE:** The Level Trim value is not stored as part of a preset and resets each time the pedal powers up.

## Power Up Modes - Output Mode



1 Press and hold the **ON** footswitch while connecting power to the pedal. Once both LEDs flash, release the footswitch.

2 Turn the **DRIVE** knob to select the desired mode. **FAV** LED indicates status.

### Amp Bypass mode - **GREEN**

Cab and Room processing are active, but Amp processing is disabled.

### Cab Bypass mode - **AMBER**

Amp and Room processing are active, but Cab processing is disabled.

### Normal mode - **RED** (default)

Amp, Cab and Room processing are active.

3 Press the **ON** or **FAV** footswitch to exit and store the Output mode setting.

**NOTE:** All Power Up functions persist through power cycles. During normal operation, the **ON** LED will take on the color of the selected mode when processing is enabled.

## Power Up Modes - Input Level



1 Press and hold the **FAV** footswitch while connecting power to the pedal. Once both LEDs flash, release the footswitch.

2 Turn the **DRIVE** knob to select the Input Level mode. **FAV** LED indicates status.

**Instrument - GREEN** (default)

Input headroom set for guitar level source.

**Line - RED**

Use with line level source. Adds 10dB of headroom.

3 Press the **ON** or **FAV** footswitch to exit and store the Input Level mode.

**NOTE:** All Power Up functions persist through power cycles.



## Power Up Modes - EXP Jack Options

- 1 Press and hold the **FAV** footswitch while connecting power to the pedal. Once both LEDs flash, release the footswitch.
- 2 Turn the **LEVEL** knob to select the EXP Jack functionality. **ON** LED indicates status.



**NOTE:** All Power Up functions persist through power cycles.

### Expression - **GREEN** LED

Connect a TRS expression pedal to remotely control knob settings.

*(See [page 19](#) for configuration details.)*

### Volume PRE - **AMBER** (default)

Connect a TRS expression pedal to function as a volume pedal located before the amp, cab and room.

### Volume POST - **RED**

Connect a TRS expression pedal to function as a volume pedal located after the amp and cab, but before the room.

### Digital - **BLUE**

- Connect a MultiSwitch Plus to remotely select three (3) presets.  
*(See [page 21](#) for configuration details.)*
- Connect a MIDI EXP cable or MIDI > TRS interface to access 300 presets and remotely control patch parameters via MIDI.  
*(See [page 23](#) for configuration details.)*

### External Favorite - **PURPLE**

Connect a MiniSwitch to toggle the on-board Favorite setting on and off remotely. The on-board FAV switch is disabled when External Favorite EXP mode is selected and a MiniSwitch is connected to the EXP jack.

*(See [page 18](#) for configuration details.)*

- 3 Press the **ON** or **FAV** footswitch to exit and store the EXP Jack setting.

## External Control – External Favorite Switch Setup

Connect a Strymon MiniSwitch with a TRS cable to toggle the on-board Favorite preset on and off.

- 1 Configure the **EXP** jack for External Favorite mode.  
*(See [page 17](#) for more info.)*



- 2 Connect an external switch with a TRS cable to the **EXP** jack of Iridium.

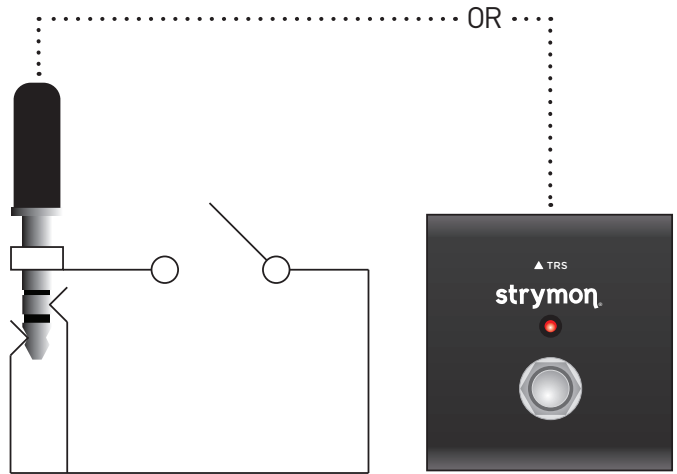

- 3 To save this setting as a new on-board Favorite sound, press and hold Iridium's on-board **FAV** switch for 2 seconds.

**NOTE:** The on-board **FAV** switch will not toggle the Favorite preset when Iridium is set to External Favorite mode and a MiniSwitch is connected to the **EXP** jack.

## External Control - Expression Pedal Setup

---

Use a TRS Expression pedal to control the knobs of Iridium.

- 1 Configure the **EXP** jack for Expression mode.

*(See [page 17](#) for configuration instructions.)*

- 2 Connect an Expression pedal to the **EXP** jack of Iridium using a TRS cable.

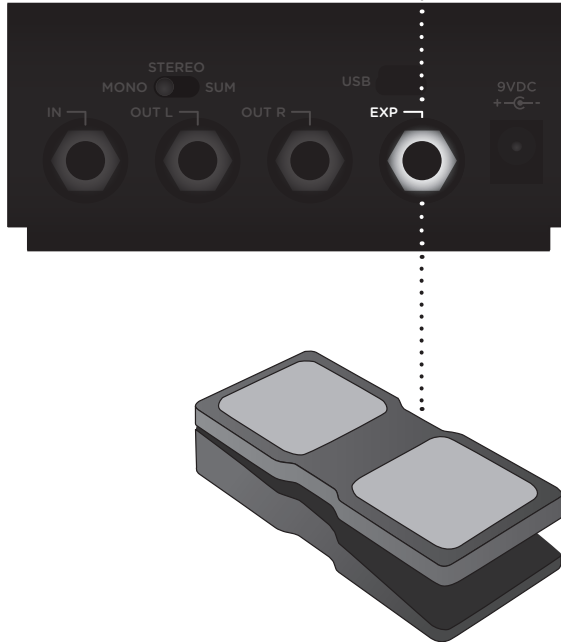

- 3 Press and hold both footswitches until both LEDs blink **GREEN**.
- 4 Rock the expression pedal to the HEEL position. Only the **FAV** LED will blink **GREEN**.
- 5 Set the knob(s) you would like to control to the desired settings for the HEEL position of the expression pedal. Only the **FAV** LED will turn **RED**.

## External Control - Expression Pedal Setup (cont.)

---

- 6 Now, rock the expression pedal to the TOE position. Now only the ON LED will blink **GREEN**.
- 7 Set the knob(s) you would like to control to the desired settings for the TOE position of the expression pedal. Only the ON LED will turn **RED**.
- 8 Press the **ON** or **FAV** footswitch to exit and store the expression pedal setup.

**NOTE:** Expression pedal assignment is saved independently per Favorite/MIDI preset.

## External Control - MultiSwitch Plus

Configure Iridium and MultiSwitch Plus for remote access to three additional presets in addition to the onboard Favorite setting.

- 1 Disconnect USB from Iridium, if connected.
- 2 Disconnect power from Iridium and reconnect while holding down both footswitches. Hold until both LEDs stop blinking.
- 3 Turn the **DRIVE** knob all the way counter-clockwise to set the MIDI channel to Channel 1. The **FAV** LED should be **GREEN**.
- 4 Turn the **LEVEL** knob all the way counter-clockwise to set the MIDI Out mode to On. The **ON** LED should be **GREEN**.
- 5 Press the **ON** or **FAV** footswitch to exit and store the MIDI channel and the MIDI Output setting.
- 6 Configure the **EXP** jack for Digital mode. *(See [page 14](#) for details.)*

- 7 Connect a TRS cable to the **EXP** jack on Iridium.



- 8 Press and hold the **A** footswitch on MultiSwitch Plus while connecting the TRS cable to MultiSwitch Plus to select Preset mode on MultiSwitch Plus.



## External Control - MultiSwitch Plus (cont.)

Selecting Iridium presets with MultiSwitch Plus:



**NOTE:** Footswitches 1, 2, and 3 on MultiSwitch Plus correspond to MIDI program changes 1, 2, and 3.

- 1 Step on a switch that is not illuminated (or the onboard FAV) to recall the relevant preset.
- 2 Step on an illuminated switch to revert to the current set of knob positions.

Saving Iridium presets with MultiSwitch Plus:

- 1 Dial in the sound that you would like to save as your preset on Iridium.
- 2 Press and hold the **FAV** footswitch until the **FAV** LED blinks **BLUE**.
- 3 Press the **A**, **B**, or **C** footswitch on MultiSwitch Plus to save the desired preset location. Press the onboard **FAV** footswitch on Iridium to save to the desired location.

**NOTE:** The onboard FAV footswitch preset on Iridium corresponds to MIDI program change 0.

## Configuring Iridium to Use MIDI

Using MIDI unlocks a set of tools that can be used to load any of Iridium's 300 preset locations and automate knob changes using a suitable MIDI controller or interface connected to Iridium's **EXP** jack. This requires a MIDI controller/interface with at least one quarter-inch output or a Strymon MIDI EXP cable.

Check [strymon.net/support/iridium](http://strymon.net/support/iridium) for a list of compatible devices.

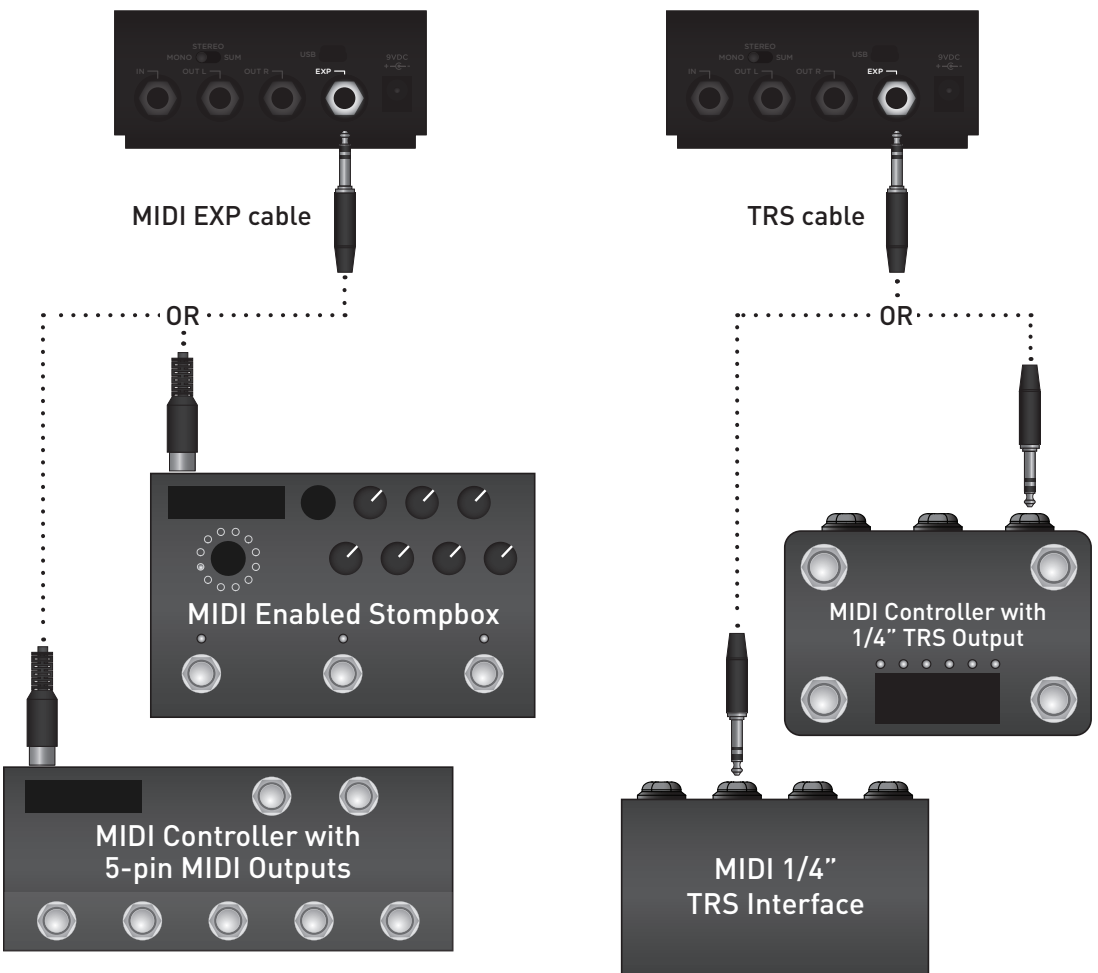

## Configuring Iridium to Use MIDI (cont.)

### Step 1 – Set EXP to Digital Mode

- 1 Press and hold the **FAV** footswitch while connecting power to the pedal. Once both LEDs flash, release the footswitch.
- 2 Turn the **LEVEL** knob until the **ON** LED is **BLUE**.
- 3 Press the **ON** or **FAV** footswitch to exit and store the EXP Jack setting.



**NOTE:** If you are only sending data to Iridium – the most common configuration – the MIDI Output mode must be set to OFF.  
*(See [page 23](#) for details on configuring the MIDI Output Mode.)*



## Configuring Iridium to Use MIDI (cont.)

### Step 2 – Set MIDI Channel

This determines which MIDI channel Iridium will use to send and receive MIDI data. See the illustrated guide below for complete instructions. To select channel 4-16, you will need to connect Iridium to a MIDI device.

1 Disconnect USB from Iridium, if connected.

2 Press and hold both footswitches while connecting power to the pedal. Once both LEDs flash, release the footswitches.

3 Turn the **DRIVE** knob to set the MIDI communication channel. **FAV** LED indicates status.



Channel 1 - **GREEN** (default)

Channel 2 - **AMBER** Channel 2

Channel 3 - **RED**

Channel 4-16 - **BLUE** (Requires ¼" MIDI connection.) Once the LED turns **BLUE**, it will blink until the pedal receives a MIDI Program Change message. Once a message is received, the pedal will be set to the MIDI channel that carried the message and the LED will stop blinking.

4 Press the **ON** footswitch again to store the MIDI channel and begin.

## Configuring Iridium to Use MIDI (cont.)

### Step 3 – Set MIDI Output Mode

This determines what kind of MIDI data is sent out by Iridium. Note that if you are only sending MIDI data to Iridium – the most common configuration – the MIDI Output mode must be set to OFF.

1 Disconnect USB from Iridium, if connected.

2 Press and hold both footswitches while connecting power to the pedal. Once both LEDs flash, release the footswitches.

3 Turn the **LEVEL** knob to select what kind of MIDI data is sent from Iridium to other MIDI devices. Both LEDs flash momentarily to indicate status.



#### ON - GREEN

Using Iridium's knobs and switches generates MIDI messages that are sent out of Iridium. (Set to ON when using MultiSwitch Plus.)

#### THROUGH - AMBER

Incoming MIDI messages are sent out of Iridium without any additional MIDI messages generated by Iridium.

#### OFF - RED (default)

No MIDI messages are sent out of Iridium.

4 Press the **ON** or **FAV** footswitch again to set the MIDI output channel and exit.

**TIP:** A simple way to check that communication is working is to send CC #27 with a value of 127 when the **FAV** footswitch is off. This will turn the **FAV** footswitch on if MIDI is properly connected and configured.

## MIDI Functionality - MIDI Expression On/Off

This setting selects whether Iridium will respond to incoming MIDI Expression messages. If your rig uses MIDI Expression messages with multiple pedals that are set to the same MIDI Channel, this setting can be used to determine which pedal(s) will respond to expression messages for a given preset.

- 1 Press and hold the **ON** footswitch until both LEDs flash, then release the footswitch.

- 2 Turn the **MIDDLE** knob to select whether Iridium will respond to incoming MIDI Expression messages (CC #100). **ON** LED indicates status.



### OFF - RED

Iridium will not respond to MIDI Expression messages.

### ON - BLUE (default)

Iridium will respond to MIDI Expression messages.

- 3 Press the **ON** or **FAV** footswitch to store the setting to Iridium.

**NOTE:** MIDI Expression setting is saved per preset.

## MIDI Functionality - Saving Presets with MIDI

When in MIDI mode, the currently loaded settings can be saved to any of Iridium's 300 preset locations at any time.

- 1 To enter SAVE mode, press and hold the **FAV** footswitch. The LED will blink **BLUE** to indicate that it is waiting to receive a MIDI Program Change message.



- 2 Send the unit a MIDI Program Change message from the connected MIDI device. The LED will flash and Iridium will save the settings to that preset location.

:

(OR)

:

To save the preset to the currently loaded preset location, press the **FAV** footswitch.

## MIDI Specifications

---

### MIDI PROGRAM CHANGES

Iridium contains 300 preset locations, numbered sequentially from 0-299. Because MIDI Program Change messages have a maximum number of 128 (0-127) the presets are grouped into three MIDI patch banks.

**MIDI BANK 0 = PRESETS 0-127**

**MIDI BANK 1 = PRESETS 128-255**

**MIDI BANK 2 = PRESETS 256-299**

Iridium always powers up in MIDI Patch Bank 0, so if you plan to stay within the first 127 presets, simply send a standard MIDI Program Change message to load a preset.

If you will be using MIDI Banks 1 and/or 2, it is advisable to send a standard MIDI Bank Change message (MIDI CC# 0 with a value equal to the MIDI Bank#) before each MIDI Program Change.

Selecting bank 0, patch 127 will put Iridium into Manual mode. In this mode, the pedal will be set to the current knob and switch settings. No preset data can be stored at this preset location.

## MIDI Specifications (cont.)

### MIDI CC NUMBERS

PARAMETERS	CC#	RANGE	NOTES
Bank Select	0	0-2	
Volume Pedal	7	0-127	
Volume Pedal Pre/Post	9	0, 127	(0=pre, 1-127=post)
Level	12	0-127	
Drive	13	0-127	
Bass	14	0-127	
Mid	15	0-127	
Treble	16	0-127	
Room Level	17	0-127	
Room Size	18	1-3	(1=small, 2= medium, 3= large)
Amp	19	1-3	(1=round, 2=chime, 3=punch)
Cab	20	0-2	(round a, b, c)
	20	3-5	(chime a, b, c)
	20	6-8	(punch a, b, c)
Footswitch Fav	27	0, 127	(0=release, 1-127=press)
Footswitch On	28	0, 127	(0=release, 1-127=press)
MIDI Expression Off/On	60	0, 127	(0=off, 1-127=on)
Expression Pedal	100	0-127	
Bypass/On	102	0, 127	(0=bypass, 1-127=on)

## Factory Reset

Factory Reset restores Iridium to its factory default state by erasing all custom IR cabs, stored presets, Power Up modes, expression pedal assignments, and Live Edit parameters.



- 1 Press and hold the **ON** footswitch while connecting power to the pedal. Once both LEDs flash, release the footswitch.

- 2 Sweep the **MIDDLE** knob from 0% to 100% and back twice to **RESET**. The status is shown on both LEDs:

Turn 1 - **AMBER**

Turn 2 - **RED**

Turn 3 - **AMBER**

Turn 4 - Both LEDs blink **RED**, pedal resets, and power cycles

**NOTE:** Performing a Factory Reset will erase all custom IRs you have loaded into Iridium and replace them with the factory default IRs.

## Features

.....

- Three Matrix Modeled™ amps with the sound, feel, and response of classic tube amps
- Nine Impulse Response speaker cabinets (three per amp type) - 24bit / 96kHz 500ms Stereo, pre-loaded with a curated set of IRs from popular IR providers
- Hybrid IR/algorithmic Room control with selectable small/medium/large room sizes
- Simple, responsive amp-style controls for Drive, Level, Bass, Middle, and Treble
- Stereo Input (requires TRS adapter cable) and Stereo Output
- Selectable Input Level for Instrument or Line Level input sources
- Premium stereo high impedance discrete JFET analog front end with up to 22dB of pure analog gain
- Discrete transistor headphone amplifier with 1/8" output
- Dedicated footswitch to save and recall a Favorite setting
- Compatible with Strymon MultiSwitch Plus and MiniSwitch for remote selection of up to (3) three presets in addition to the onboard Favorite
- Expression pedal input provides seamless morphing between knob positions (Expression mode), or smooth pre/post volume control with logarithmic taper (Volume mode)
- USB jack for connecting to free Strymon Impulse Manager software to load and edit your own speaker cabinet IRs
- Full featured MIDI accessible via EXP Jack for remote parameter control and access to 300 preset locations (requires Strymon MIDI EXP cable or MIDI > TRS interface)
- Ability to globally bypass amps and cabs independently
- Ultra-low noise, high performance 24-bit 96kHz A/D and D/A converters provide uncompromising audio quality
- Super high performance SHARC DSP
- 32-bit floating point processing
- Designed and built in the USA



## Specifications

.....

<b>Input Impedance</b>	1M Ohm
<b>Output Impedance</b>	100 Ohm
<b>A/D &amp; D/A</b>	24-bit 96kHz
<b>Max Input Level</b>	+8dBu
<b>Frequency Response</b>	20Hz to 20kHz
<b>Signal to Noise</b>	110dB typical
<b>DSP performance</b>	1585 MegaFLOPS
<b>Bypass Switching</b>	buffered bypass
<b>Dimensions</b>	4.5" deep x 4" wide x 1.75" tall (11.4 cm deep x 10.2 cm wide x 4.4 cm tall)

## Power Adapter Requirements

.....

Use an adapter with the following rating: 9VDC center negative; 500mA minimum.

## US Registered Trademarks

.....

Fender®, Deluxe Reverb®, Blues Junior®, and Vibrolux® are registered trademarks of Fender Musical Instruments Corporation. Vox® is a registered trademark of Vox R&D Limited. Marshall® is a registered trademark of Marshall Amplification Plc. Mesa/Boogie®, Half-Back®, and Black Shadow® are registered trademarks of Mesa/Boogie, Ltd. Celestion® is a registered trademark of Rola Celestion, Ltd. Electro-Voice® is a registered trademark of Robert Bosch, GmbH. Jensen® is a registered trademark of Sica Altoparlanti S.R.L.

Appendix 1

**Live Edit Functions and  
Power Up Modes**

## Live Edit Functions Quick Reference

Below is a list that details how to access parameters that are adjustable from Iridium's interface but do not have dedicated knobs or switches.

Press and Hold the **ON** footswitch until both LEDs start blinking to enter Live Edit mode. Release the footswitch and use knobs as described below.

Press **ON** or **FAV** to store your changes and exit Live Edit mode.

### ROOM SIZE

*(See [page 13](#) for an illustrated description.)*

Turn **ROOM** knob - status shown on **ON** LED

Small = **GREEN**

Medium = **AMBER**

Large = **RED**

### MIDI EXPRESSION ON/OFF

*(See [page 27](#) for an illustrated description.)*

Turn **MIDDLE** knob - status shown on **BOTH** LEDs

Off = **RED**

On = **BLUE**

### LEVEL TRIM

*(See [page 14](#) for an illustrated description.)*

Turn **LEVEL** knob - status shown on **FAV** LED

-10 dB = **GREEN**

0 dB = **RED**

+3 dB = **AMBER**

## Power Up Modes Quick Reference

Power Up functions persist through power cycles. Return all function defaults with factory reset.

Press and Hold the **ON** footswitch while connecting power to Iridium until both LEDs start blinking to enter Power Up mode. Release the footswitch and use knobs as described below.

Press **ON** or **FAV** to store your changes and exit.

### OUTPUT MODE

*(See page 15 for an illustrated description.)*

Turn **DRIVE** knob - status shown on **FAV** LED

Amp Bypass = **GREEN**

Cab Bypass = **AMBER**

Normal = **RED**

### FACTORY RESET

*(See page 31 for an illustrated description.)*

Turn **MIDDLE** knob - status shown on **BOTH** LEDs. Turn the **MIDDLE** knob from 0-100% and back two (2) times.

Press and Hold the **FAV** footswitch while connecting power to Iridium until both LEDs start blinking to enter Power Up mode. Release the footswitch and use knobs as described below.

Press **FAV** again to store your changes and exit.

### INPUT LEVEL

*(See page 16 for an illustrated description.)*

Turn **DRIVE** knob - status shown on **FAV** LED

Instrument = **GREEN**

Line = **RED**

### EXP JACK MODE

*(See page 17 for an illustrated description.)*

Turn **LEVEL** knob - status shown on **ON** LED

Expression - **GREEN**

Volume PRE - **AMBER**

Volume POST - **RED**

Digital - **BLUE**

External Favorite - **PURPLE**

## MIDI Power Up Settings Quick Reference

Below is a list that details how to access all Power Up parameters that are adjustable from Iridium's interface and do not have dedicated knobs or switches. Power Up functions persist through power cycles. Return all function defaults with factory reset.

Disconnect USB from Iridium, if connected. Press and Hold the **FAV** and **ON** footswitch while connecting power to Iridium until both LEDs start blinking to enter Live Edit mode. Release the footswitches and use knobs as described below.

Press **FAV** again to store your changes and exit.

### MIDI CHANNEL

*(See [page 25](#) for an illustrated description.)*

Turn **DRIVE** knob - status shown on **FAV** LED

1 - **GREEN**

2 - **AMBER**

3 - **RED**

4-16 - **BLUE**

### MIDI OUTPUT MODE

*(See [page 26](#) for an illustrated description.)*

Turn **LEVEL** knob - status shown on **ON** LED

On = **GREEN**

Through = **AMBER**

Off = **RED**

Appendix 2  
**IR Cab Details**

## Cab File Details - round

---

Iridium's curated cabinet IRs are based on\* the following:

### round - a

Name: 112 DVRB (stereo)  
Cab: 1x12 Fender® Deluxe Reverb®  
Speaker: Fender® CTS ceramic  
Provided by: OwnHammer  
File Name: OH 112 DVRB CTS.wav

### round - b

Name: 112 FE-Junior (mono)  
Cab: 1x12 Fender® Blues Junior®  
Speaker: Jensen® C12N  
Provided by: cabIR.eu  
File Name: JUNIOR\_FOCUS\_CAB.wav

### round - c

Name: 212 FE-VLUX65 (stereo)  
Cab: 2x10 Fender® Vibrolux®  
Speaker: Jensen® C10NS  
Provided by: cabIR.eu  
File Name: VLUX65-M-Re1-15-Re2-15.wav

\*All product names are trademarks of their respective owners, which are in no way associated or affiliated with Strymon. These product names, descriptions and images are provided for the sole purpose of identifying the specific products that were studied during Strymon's sound design process. See [page 34](#) for a list of U.S. registered trademarks.



## Cab File Details - chime

---

Iridium's curated cabinet IRs are based on\* the following:

### chime - a

Name: 212 V30 Blue (stereo)  
Cab: 2x12 Vox<sup>®</sup> AC30/6 open back fawn  
Speaker: Celestion<sup>®</sup> T0530 Blue AlNiCo  
Provided by: OwnHammer  
File Name: OH 212 VC30 BLU-12C CLASC-06.wav

### chime - b

Name: 112 Blue Closed (mono)  
Cab: 1x12 custom closed back  
Speaker: Celestion<sup>®</sup> Blue AlNiCo  
Provided by: Celestion<sup>®</sup>  
File Name: Cel Blue 112 C Hi-Gn 421+57 Celestion.wav

### chime - c

Name: 412 V2-MHB (mono)  
Cab: 4x12 Mesa/Boogie<sup>®</sup> Half-Back<sup>®</sup>  
Speaker: Celestion<sup>®</sup> Black Shadow<sup>®</sup> MC-90 + Electro-Voice<sup>®</sup>  
Black Shadow<sup>®</sup> EVM12-L  
Provided by: Valhallir.at  
File Name: V2-MHB412-d-e906-C5.wav

\*All product names are trademarks of their respective owners, which are in no way associated or affiliated with Strymon. These product names, descriptions and images are provided for the sole purpose of identifying the specific products that were studied during Strymon's sound design process. See [page 34](#) for a list of U.S. registered trademarks.

## Cab File Details - punch

---

Iridium's curated cabinet IRs are based on\* the following:

### punch - a

Name: 412 MRBW GNR (stereo)  
Cab: 4x12 Marshall®  
Speaker: Celestion® T1221 G12M-25  
Provided by: OwnHammer  
File Name: OH 412 MRBW M75-GNR BROWN-00.wav

### punch - b

Name: 212 V30 Open (mono)  
Cab: 2x12 custom open back  
Speaker: Celestion® Vintage 30  
Provided by: Celestion®  
File Name: V30 212 O R-121 Dark2 Celestion.wav

### punch - c

Name: Punch C: 812 PETE (mono)  
Cab: 8x12 Marshall®  
Speaker: Celestion® T652 AlNiCo  
Provided by: cabIR.eu  
File Name: PETE\_CAB\_M01\_MULTI\_I.wav

\*All product names are trademarks of their respective owners, which are in no way associated or affiliated with Strymon. These product names, descriptions and images are provided for the sole purpose of identifying the specific products that were studied during Strymon's sound design process. See [page 34](#) for a list of U.S. registered trademarks.

Appendix 3  
**Audio Routing**

## Audio Routing - MONO Input

Mono signal (e.g. a guitar or pedal) connected to IN. Stereo Output appears at OUT L and OUT R.

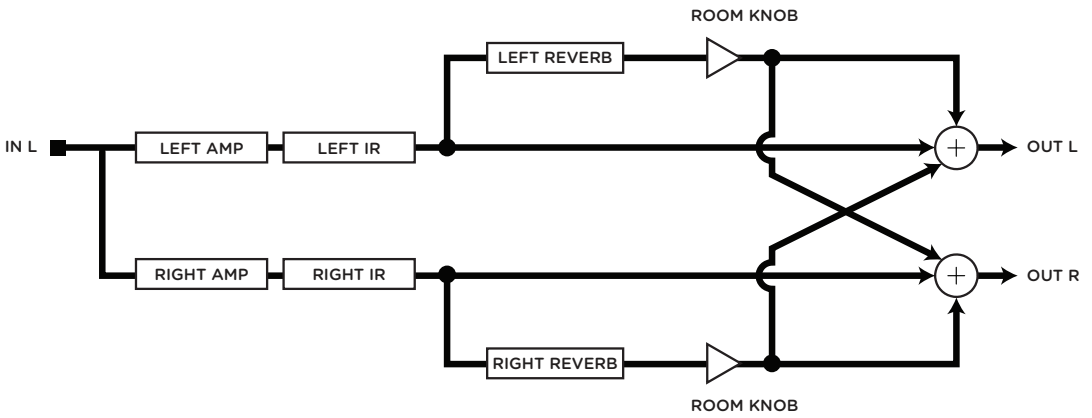
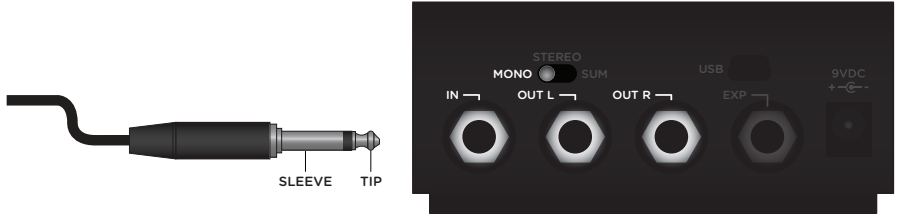

## MONO BYPASS

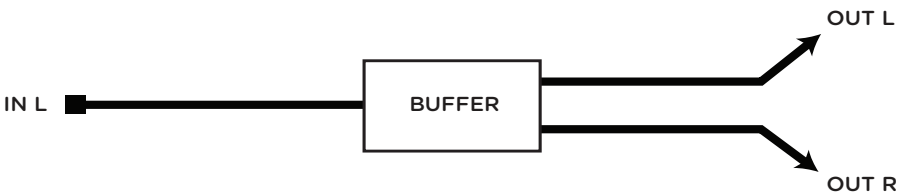

## Audio Routing - STEREO Input

Stereo signal is connected to IN via a TRS cable. Stereo output appears at OUT L and OUT R.

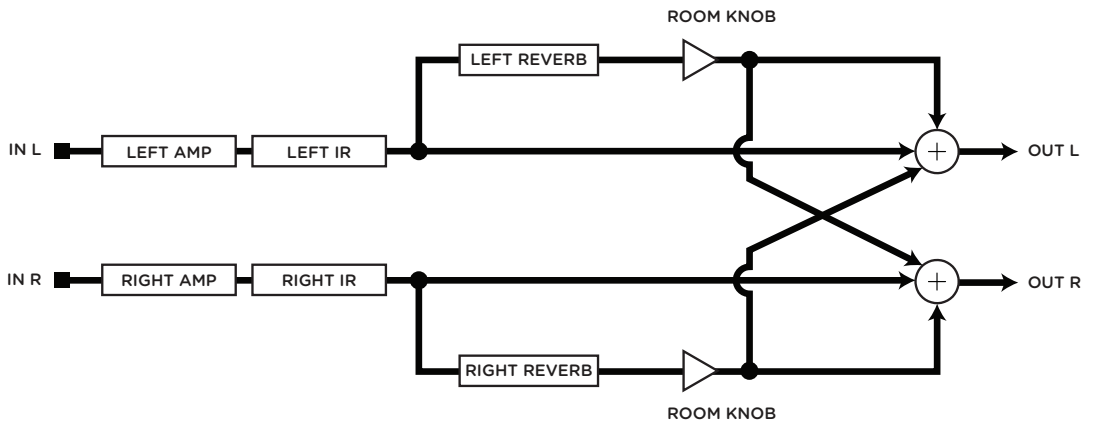
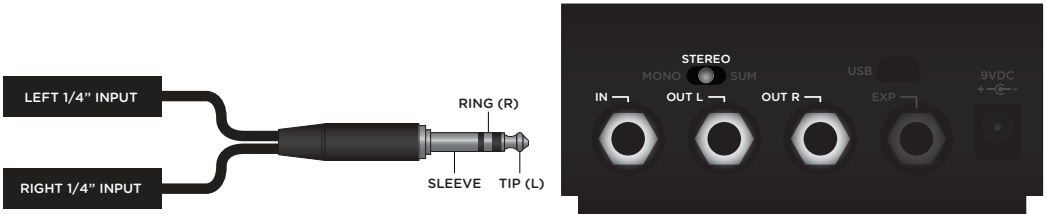

## STEREO BYPASS

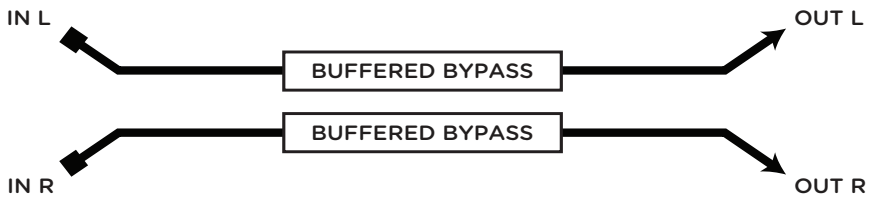

## Audio Routing - SUM Input (Stereo In - Mono Out)

Stereo signal is connected to IN via TRS cable. The stereo signal is summed to mono, and mono output appears at OUT L.

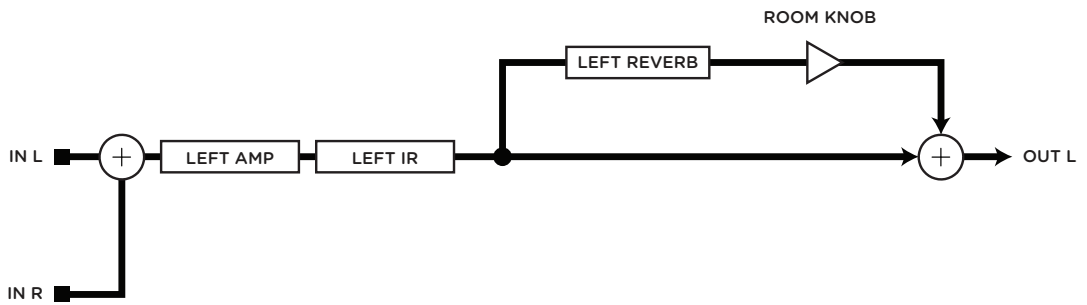
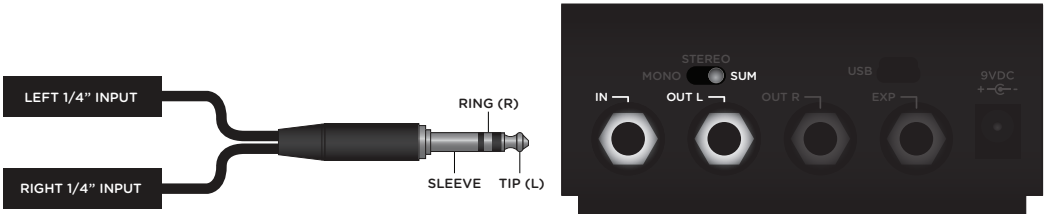

## SUM BYPASS

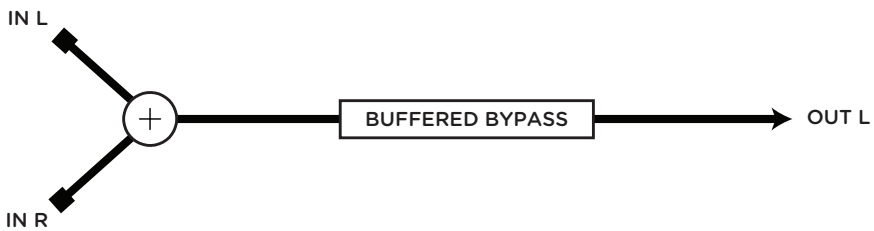

Appendix 4  
**Sample Settings**



**CLEAN JANGLE**  
Room Size: Small  
(onboard Favorite setting)



**CLASSIC CLEAN**  
Room Size: Medium



**CROWN JEWEL**  
Room Size: Medium



**PUNCHED UP**  
Room Size: Large



## Strymon Non-Transferrable Limited Warranty

---

### Warranty

Strymon warrants the product to be free from defects in material and workmanship for a period of two (2) years from the original date of purchase when bought new from an authorized dealer in the United States of America or Canada. If the product fails within the warranty period, Strymon will repair or, at our discretion, replace the product at no cost to the original purchaser. Please contact your dealer for information on warranty and service outside of the USA and Canada.

### Exclusions

This warranty covers defects in manufacturing discovered while using this product as recommended by Strymon. This warranty does not cover loss or theft, nor does the coverage extend to damage caused by misuse, abuse, unauthorized modification, improper storage, lightning, or natural disasters.

### Limits of Liability

In the case of malfunction, the purchaser's sole recourse shall be repair or replacement, as described in the preceding paragraphs. Strymon will not be held liable to any party for damages that result from the failure of this product. Damages excluded include, but are not limited to, the following: lost profits, lost savings, damage to other equipment, and incidental or consequential damages arising from the use, or inability to use this product. In no event will Strymon be liable for more than the amount of the purchase price, not to exceed the current retail price of the product. Strymon disclaims any other warranties, expressed or implied. By using the product, the user accepts all terms herein.

### How to Obtain Service Under this Warranty

For North American customers: Contact Strymon through our website at [strymon.net/support](http://strymon.net/support) for Return Authorization and information. Proof of original ownership may be required in the form of a purchase receipt.

For International Customers: Contact the Strymon dealer from which the product was purchased from in order to arrange warranty repair service.

Strymon® is a division of Damage Control Engineering®, LLC.